

e lektor

UltraProp Clock

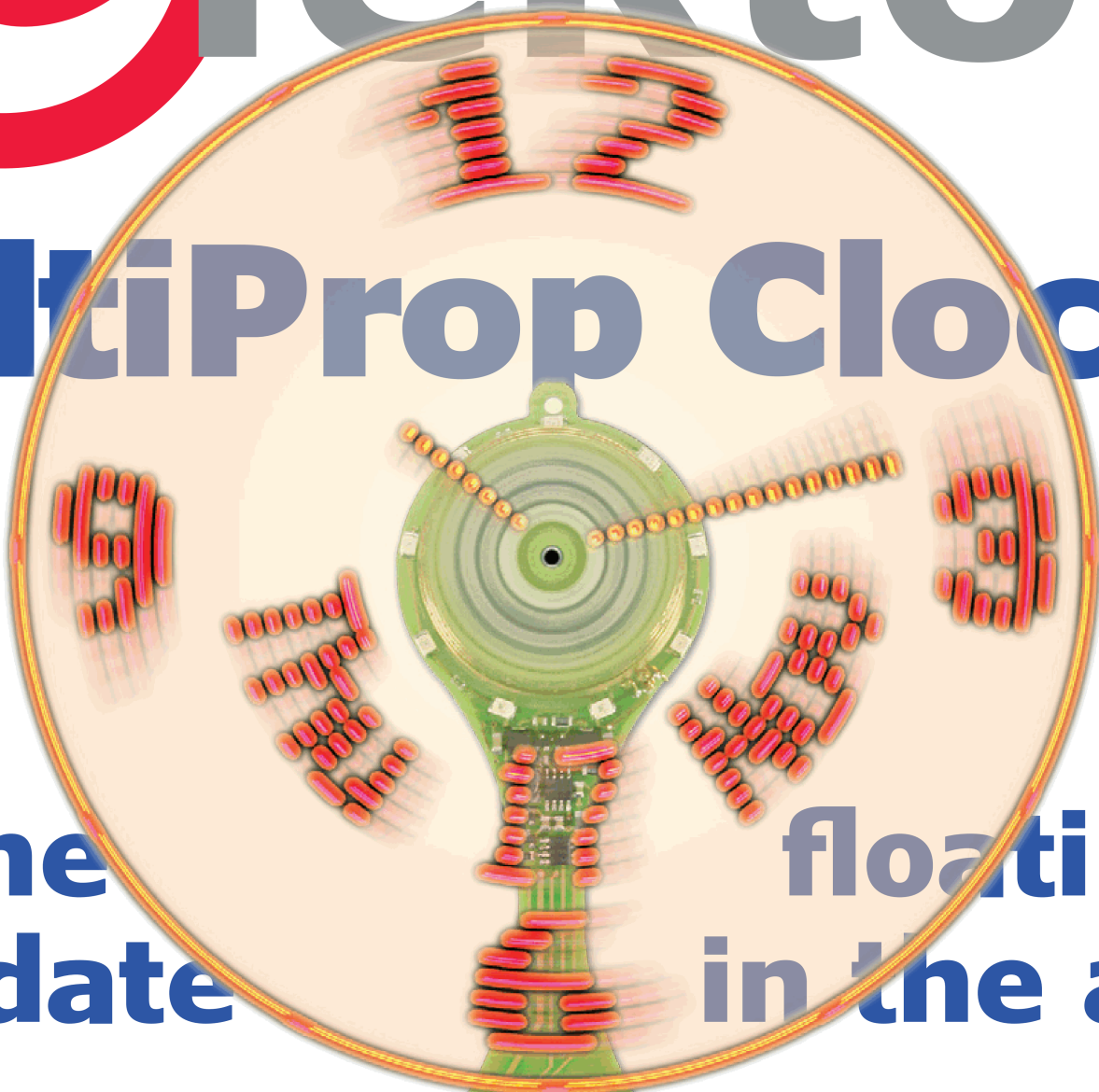

time
& date

floating
in the air

- **Multi I/O for FPGA Dev**
- Network Tester | **USB**
- Enter BeagleBone Black
- Hood ● **Surfin' the RPi Wave**
- Insulation Tester ● **Microgrids**

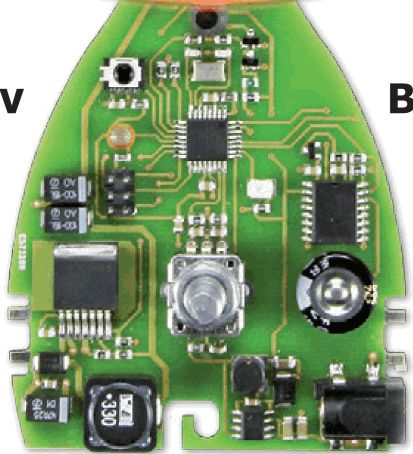

- Board** | Home and Office
- Battery Tester**
- FlowStone | **Joule Robbin'**
- **Bendix Hi-Pot**



Your competent
online partner for

Components
Power supply systems
Measuring technology

Shop & soldering technology
Home & security technology
Network technology

PC technology
Sat/TV technology
Communication



The 3D printer

Innovative & compact – Made in Germany

"Unlimited creativity"

Experience the fabbster
3D printer in action:



<http://rch.lt/ci>

3D printer kit Create your project!

The fabbster is a 3D printer for
office, home and hobby use.
fabbster makes three-dimensional
models designed on your PC
or MAC into real objects you
can touch.

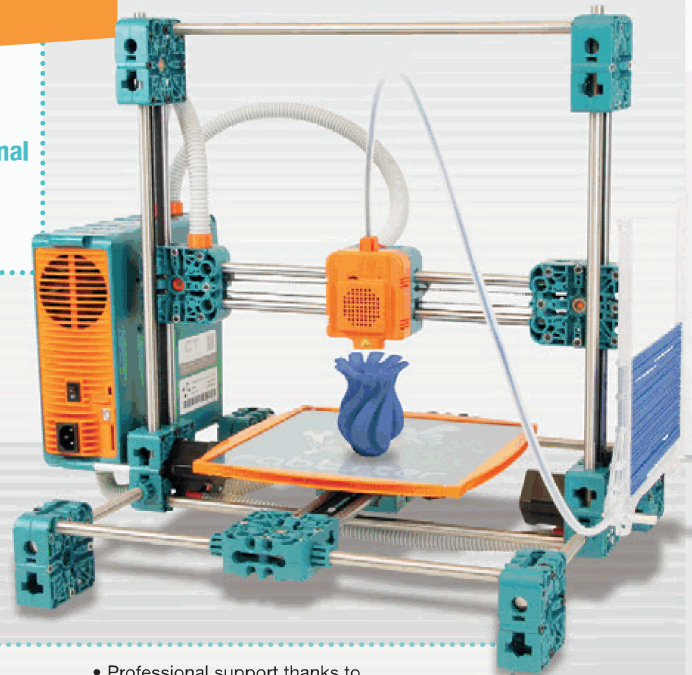

Your idea in 3D

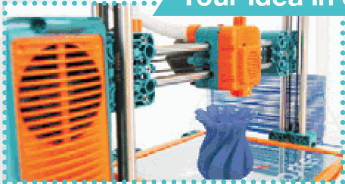

€ **1499,00**
(~ £ 1277,-)

FABBSTER G KIT



The appliance is equipped with an
earthed connector plug. A connecting
cable for your country can be found
on the article page in our online shop.

Max. model size:
23 x 23 x 21 cm

- Precise and reliable material system:
STICK DEPOSITION MOULDING (SDM)
- Multi-coloured 3D printing:
Give colour to your ideas!
- Largest printer in its class: 3D objects can
be printed with an edge length of 20 cm

- Professional support thanks to
industrial backup: reliable supply chain
- **Specially adapted software**
"netfabb for fabbster" included
- Award-winning design
- Made in Germany

DM Stick Deposition Moulding



Objects can be printed in multiple colours



SDM – Stick Deposition Moulding Material for fabbster 3D printer

In Stick Deposition Moulding the extruder is loaded
with original fabbster LIKE sticks, which are profiled on the side.
These sticks offer the advantage of non-slip feeding as opposed
to conventional circular filament material. The result is precise
dosage of the melted material and objects with optimal material
properties.

We offer sticks in the following colours:
black, white, blue, yellow, green, orange,
red, pink, silver, light blue and natural

100 sticks/200 g

ABS FABBSTER ...

€ **14,95**
(~ £ 12,74)

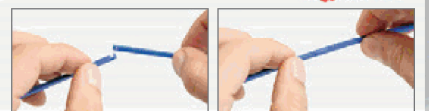
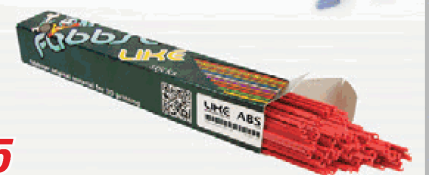

Order now! www.reichelt.com

English Hotline: +49 (0)4422 955-360

Daily prices! Prices as of: 28/10/2013

For consumers: The statutory right of withdrawal for consumers shall apply. All stated prices in € include the legal value added tax, ex works Sande/Germany, plus forwarding charges for the entire shopping cart. Our general terms and conditions shall apply exclusively (under www.reichelt.com/agb). Subject to prior sale. All brands, product names and logos are property of the respective manufacturers. Images can be similar. Subject to misprint, errors and changes in prices. reichelt elektronik GmbH & Co. KG, Elektroniking 1, 26452 Sande/Germany (HRA 200654 Oldenburg)

International payment method: 



AVAILABLE NOW

DISPLAY MADE EASY

EVE EMBEDDED VIDEO ENGINE

A REVOLUTIONARY SOLUTION ENABLING HI-QUALITY, HUMAN MACHINE INTERFACES AT A LOWER COST



DEVELOPMENT SYSTEMS FROM

\$35



DISPLAY AUDIO TOUCH

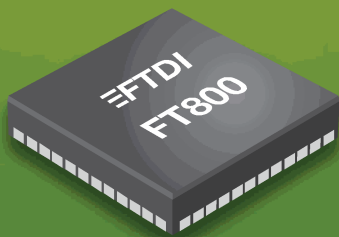

WATCH EVE DEMOS ONLINE



FTDICHIP.COM

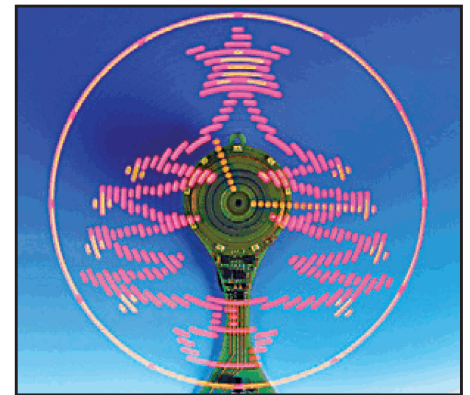

● Community

8 Elektor World

- The Electronic Roundabout: tell us a new story!
- Clouds—as we know them
- Start Printing in 3D!
- And more
- Security
- The Gate

● Projects

10 UltiProp Clock (1)

This article gives you the key details that hopefully will enable you to successfully build your own high-quality clock, which is bound to draw admiring, envious cries of “Wow!” from your guests. It’s high time you too discover Elektor’s Ulti(mate) Prop(eller) Clock.

22 Multi I/O for FPGA Development Board (1)

Elektor’s December 2012 FPGA is expanded with:
GPS receiver; temperature sensor; pressure sensor; RGB color sensor; 2 x 16 character LCD; 4 pushbuttons; 4 LEDs; rotary encoder; 7 external digital expansion pins; and 3 external analog inputs.

32 Home and Office Network Tester

The circuit presented here offers easy one-button testing of common home and office networks, with red-amber-green indication of the network status, and any faults. The design is really simple, just a microcontroller, an Ethernet interface, a pushbutton for starting the test and status LEDs to show the condition of the network. Still, it does do a lot more than a simple cable tester.

40 USB Battery Tester

Testing batteries is a fairly common task among electronics enthusiasts. Instead of using a complex stand-alone meter, you

can put the intelligence of a PC to good use for this. Here we add a battery interface to the general-purpose USB-I2O4 cable presented in a previous edition of Elektor magazine.

48 Enter BeagleBone Black

Yet another platform has been released to the embedded audience: the BeagleBone Black. Recently we (finally) got one on our workbench. It looks like a very promising platform with powerful hardware and a lot of potential. Does it outperform the Raspberry Pi?

52 The Flowstone of Wisdom

There are many visual programming languages out there, but Flowstone is one with a twist. Clemens Valens examines.

56 Joule Robbin’ Hood

This circuit steals (energy) from the rich (batteries) and gives it to the poor (plants).

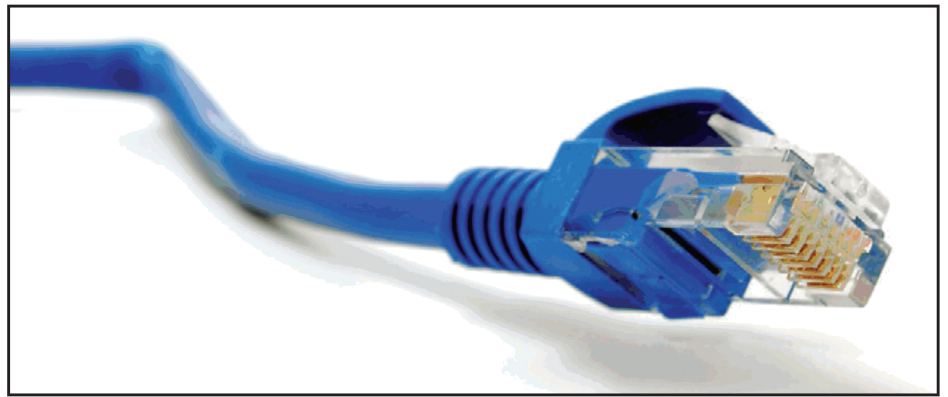
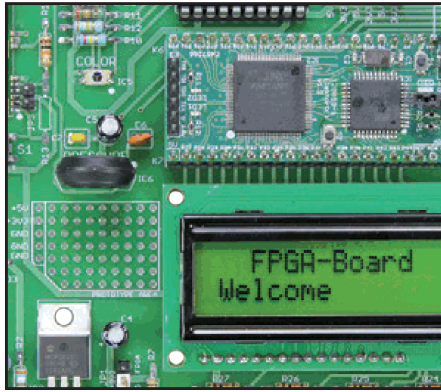
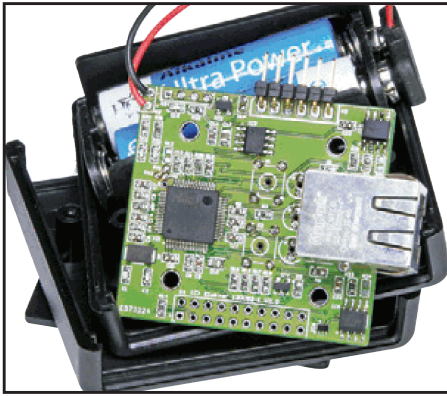

● DesignSpark

- 58 **DesignSpark Tips & Tricks Day #6: after the layout**
DesignSpark's online BOM and PCB quoting tools enable you to find out how much it would cost to build our example project. These tools can be a great time saver.

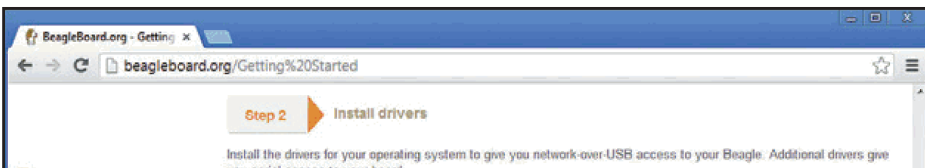

● Labs

- 62 **Surfin' the RPi Wave**
An overview of Raspberry Pi based projects currently lining up at www.elektor-labs.com, including outlines of RPi Prototyping, mass storage and refrigerator monitoring.

● Industry

- 64 **News & New Products**
A selection of news items received from the electronics industry, labs and organizations.

● Tech The Future

- 68 **Microgrids**
Microgrids are one of the answers to the question of how to increase the share of sustainable sources in the energy mix. TTF investigates on the Faroe Islands.

● Magazine

- 70 **Bendix 60B4-1-A AC/DC Insulation Tester**
Warning: High Potential! Chuck Hansen takes a nostalgic yet technical look at a 1960s instrument designed to check and ensure electrical safety. Series Editor: Jan Buiting.
- 76 **Hexadoku**
Elektor's monthly puzzle with an electronics touch.
- 77 **Gerard's Columns: Retronics Personified**
A column or two from our columnist Gerard Fonte.
- 82 **Next Month in Elektor**
A sneak preview of articles on the Elektor publication schedule.

Volume 39, No. 444
December 2013

ISSN 1947-3753 (USA / Canada distribution)
ISSN 1757-0875 (UK / ROW distribution)
www.elektor.com

Elektor Magazine is published 10 times a year including double issues in January/February and July/August, concurrently by

Elektor International Media
111 Founders Plaza, Suite 300
East Hartford, CT 06108, USA
Phone: 1.860.289.0800
Fax: 1.860.461.0450

and

Elektor International Media
78 York Street
London W1H 1DP, UK
Phone: (+44) (0)20 7692 8344

Head Office:

Elektor International Media b.v.
PO Box 11
NL-6114-ZG Susteren
The Netherlands
Phone: (+31) 46 4389444
Fax: (+31) 46 4370161

USA / Canada Memberships:

Elektor USA
P.O. Box 462228
Escondido, CA 92046
Phone: 800-269-6301
E-mail: elektor@pcspublink.com
Internet: www.elektor.com/members

UK / ROW Memberships:

Please use London address
E-mail: service@elektor.com
Internet: www.elektor.com/member

USA / Canada Advertising:

Peter Wostrel
Phone: 1.978.281.7708
E-mail: peter@smmarketing.us

UK / ROW Advertising:

Johan Dijk
Phone: +31 6 15894245
E-mail: j.dijk@elektor.com

www.elektor.com/advertising

Advertising rates and terms available on request.

Copyright Notice

The circuits described in this magazine are for domestic and educational use only. All drawings, photographs, printed circuit board layouts, programmed integrated circuits, disks, CD-ROMs, DVDs, software carriers, and article texts published in our books and magazines (other than third-party advertisements) are copyright Elektor International Media b.v. and may not be reproduced or transmitted in any form or by any means, including photocopying, scanning and recording, in whole or in part without prior written permission from the Publisher. Such written permission must also be obtained before any part of this publication is stored in a retrieval system of any nature. Patent protection may exist in respect of circuits, devices, components etc. described in this magazine. The Publisher does not accept responsibility for failing to identify such patent(s) or other protection. The Publisher disclaims any responsibility for the safe and proper function of reader-assembled projects based upon or from schematics, descriptions or information published in or in relation with Elektor magazine.

© Elektor International Media b.v. 2013
Printed in the USA Printed in the Netherlands

3-D Redefined: Electrical, Mechanical, Programming

It's rewarding to see Elektor readers and contributors come out of the Pure Electronics closet and give due respect to the shape, appearance and user friendliness of their 'constructions'. Thanks to the 'mechanical touch' and 3-D printing, perfectly working electronics projects previously confined to a drawer in the designer's lab can now go public and be used and enjoyed by everyone. Not built, necessarily. A properly designed case, slick appearance, compactness, light weight and a good eye for safety are the tickets to progress from nerd to esteemed product designer, even if your gizmo contains just one AVR micro and a bunch of LEDs.

The UltiProp Clock prominently featured in this edition is a fine example of electronics designed to suit—even serve—a mechanical design. After all, if that propeller does not spin properly, text or numbers will fail to appear floating in the air as promised. Consequently, the two in-panel PCBs and the way the motor is constructed should be the best of both worlds in terms of electronics and mechanical design. Or should we say three worlds, as the software also interacts at the components and functionality levels?

Less ambitious but certainly not less clever in terms of industrial design, is the USB Battery Tester on page 40, where the good old 25-pin sub-D connector resurfaces and determines the shape of a circuit board. Ten points for everyone shouting "Centronics" when you demonstrate the tester on a suspect battery, and 20 points if you can salvage and repurpose two of these connectors from an old "parallel printer" cable.

To balance out the fair number of relatively high-tech projects in this edition, Robin Hood in electronic guise on page 56 redefines the meaning of "stealing from the rich and giving to the poor". In this case, we can't see any real losers, or a conflict for that matter, as the remaining energy in "empty" batteries fated to waste disposal actually helps to help plants grow and blossom.

Enjoy reading this edition of Elektor,

Jan Buiting, Editor-in-Chief



The Team

Editor-in-Chief:	Jan Buiting
Publisher / President:	Hugo Van haecke
Membership Managers:	Shannon Barraclough (USA / Canada), Raoul Morreau (UK / ROW)
International Editorial Staff:	Harry Baggen, Eduardo Corral, Denis Meyer, Jens Nickel
Laboratory Staff:	Thijs Beckers, Ton Giesberts, Wisse Hettinga, Luc Lemmens, Mart Schroijsen, Clemens Valens, Jan Visser, Patrick Wielders
Graphic Design & Prepress:	Giel Dols
Online Manager:	Daniëlle Mertens
Market Director:	Carlo van Nistelrooy
Managing Director:	Don Akkermans



United Kingdom
Wisse Hettinga
+31 (0)46 4389428
w.hettinga@elektor.com



USA
Hugo Vanhaecke
+1 860-875-2199
h.vanhaecke@elektor.com



Germany
Ferdinand te Walvaart
+49 241 88 909-17
f.tewalvaart@elektor.de



France
Denis Meyer
+31 46 4389435
d.meyer@elektor.fr



Netherlands
Harry Baggen
+31 46 4389429
h.baggen@elektor.nl



Spain
Eduardo Corral
+34 91 101 93 95
e.corral@elektor.es



Italy
Maurizio del Corso
+39 2.66504755
m.delcorso@inware.it



Sweden
Wisse Hettinga
+31 46 4389428
w.hettinga@elektor.com



Brazil
João Martins
+31 46 4389444
j.martins@elektor.com



Portugal
João Martins
+31 46 4389444
j.martins@elektor.com



India
Sunil D. Malekar
+91 9833168815
ts@elektor.in

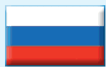

Russia
Nataliya Melnikova
+7 (965) 395 33 36
Elektor.Russia@gmail.com



Turkey
Zeynep Köksal
+90 532 277 48 26
zkoksal@beti.com.tr



South Africa
Johan Dijk
+31 6 1589 4245
j.dijk@elektor.com



China
Cees Baay
+86 21 6445 2811
CeesBaay@gmail.com

Our network



VOICE COIL

CIRCUIT CELLAR
THE WORLD'S SOURCE FOR EMBEDDED ELECTRONICS ENGINEERING INFORMATION



audio X PRESS



Connects you to

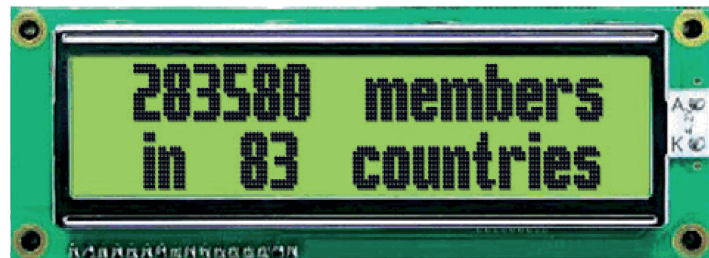

Supporting Companies



AP Circuits
www.apcircuits.com 47



Intelligent Soc s.l.
www.soclutions.com 31



Beta Layout
www.pcb-pool.com 29



Labcenter
www.labcenter.com 84



Crystalfontz
www.crystalfontz.com 47



Microchip
www.microchip.com/get/eumplabx 21



DLP Design
www.dlpdesign.com 46



Pico Technology
www.picotech.com/PS238 83



Eurocircuits
www.elektorpcbservice.com 39



Reichelt
www.reichelt.com 2



FTDI
www.ftdichip.com 3



Schaeffer AG
www.schaeffer-ag.de 46

Not a supporting company yet?

Contact Peter Wostrel (peter@smmarketing.us, Phone 1 978 281 7708,
to reserve your own space in Elektor Magazine, Elektor•POST or Elektor.com

Elektor World

Compiled by
Wisse Hettinga

Every day, every hour, every minute, at every given moment designers and enthusiasts are thinking up, tweaking, reverse-engineering and developing new electronics. Chiefly for fun, but occasionally fun turns into serious business. Elektor World connects some of these events and activities — for fun and business.

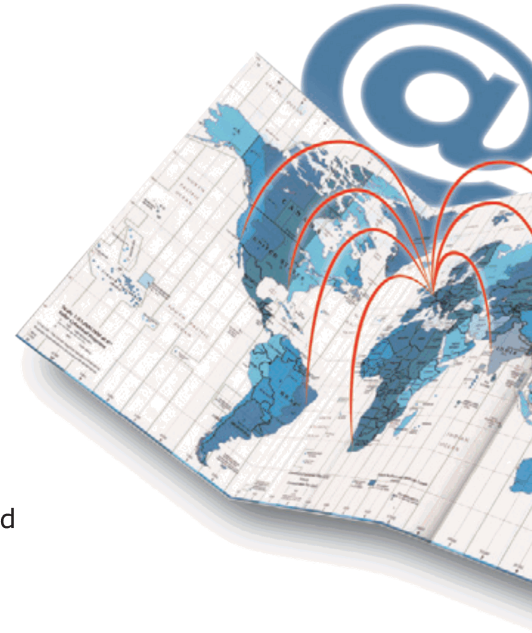

Electronic Roundabout: *tell us a new story!*



Every year Elektor RSVP's a number of freelance authors, project developers and regular contributors around the table to discuss the latest trends and technologies—in electronics of course. This year more than 50 experts joined us Hanau, near Frankfurt, Germany. In an Electronic Roundabout (three slides—three minutes floor time) a number of authors presented their work, ideas and proposals. The only briefing they got from Elektor: we've heard enough about Arduino and Raspberry Pi—please, tell us a new story! And they did.

Clouds – as we know them

Giles Harrison, Professor of Atmospheric Physics in the Meteorology department of the University of Reading, UK, kicked off with his introduction to electricity in the atmosphere, including methods of measuring the tiniest currents and voltages. A deeper understanding of this, Giles told his audience, can help predict the forming of clouds and thunderstorms. His department is launching balloons with all sorts of equipment in small payload boxes, called Pandora's. His question was; can you help define and select new sensors to fill Pandora's Box?

Find out more at www.met.reading.ac.uk/~swshargi/



Start Printing in 3D!

Makers all over the world are crazy about the latest 3D printing and laser cutting. In his presentation, Miguel Sanchez, Professor at the University of Valencia and an enthusiastic builder of huge CNC equipment, shared his passion for 3D printing and CNC gear. Being a keen maker himself he challenged the audience to test the waters called 3D technology and CNC machining.



Security

Remember this name: Nico Maas. Sounds Dutch, but he is 100% German. This student showed us why new MCU and SOC technologies need to merge. But more importantly, he stressed the need for more secure platforms—now that Arduinos are seeing increasing use in vital processes, security is becoming a necessity.

And more

Franz-Peter Zantis took us back to the basics of good old Visual Basic. He explained that there are large groups of people interested in straightforward stress-free solutions, something you can achieve easily with Visual Basic. And we had Bart Huyskens—the kind of teacher anyone would dream of having had in their student days. He works very hard to get students all over Belgium to choose Technology. Elbert Jan Van Veldhuizen, PhD, MSc, showed us the possibilities of a Universal PIC12F1840 mini board—a very versatile solution.

The Gate

Menno van der Veen is a well-known developer and author on Tube Audio equipment. Many of you will have built, bought or listened to one of his celebrated designs. Apart from Menno's love for electronics and audio he is also a fireside philosopher. He took the audience of professors and independent developers by surprise by introducing them to the deeper thinking about what motivates people, and what brings them new ideas. In his spoken parable called The Gate he challenged the audience to go a step further in making decisions and not stay in the comfort zone. Menno specifically asked to take the last turn on the Electronic Roundabout—a worthy end to a feature rich afternoon.



And then there were drinks and food and more discussions till the early morning.

UltiProp Clock (1)

time & date floating in the air

Part 1

Electronics is never so fine as when it skillfully combines magic with physics, mechanics with software, imagination with thoroughness and precision, and a taste for beauty with good workmanship. This timepiece was designed to display the time and date in an original way—but I admit I did also design it to draw cries of amazement from the visitors who find it in my lounge. I'll bet many of you will want to do the same in your own homes.

By **David Ardouin**
(France)

On the Internet, with keywords like "Propeller Clock" or "mechanical sweep display", you can find a number of projects based on this principle—but not many of these get beyond the laboratory prototype stage. Here, I'm proposing not just to discover how one works, but above all I give you the key details that hopefully will enable you to successfully build your own high-quality clock, which is bound to draw admiring, envious cries of "Wow!" from your guests. It's high time you too

discover the principle of the scanning in CRT TVs and of illuminated matrices of all types. Whatever the process, since even a fleeting image remains stamped on our retina for a few tens of milliseconds, all we have to do is refresh the display often enough to give the impression of stability or smooth movement.

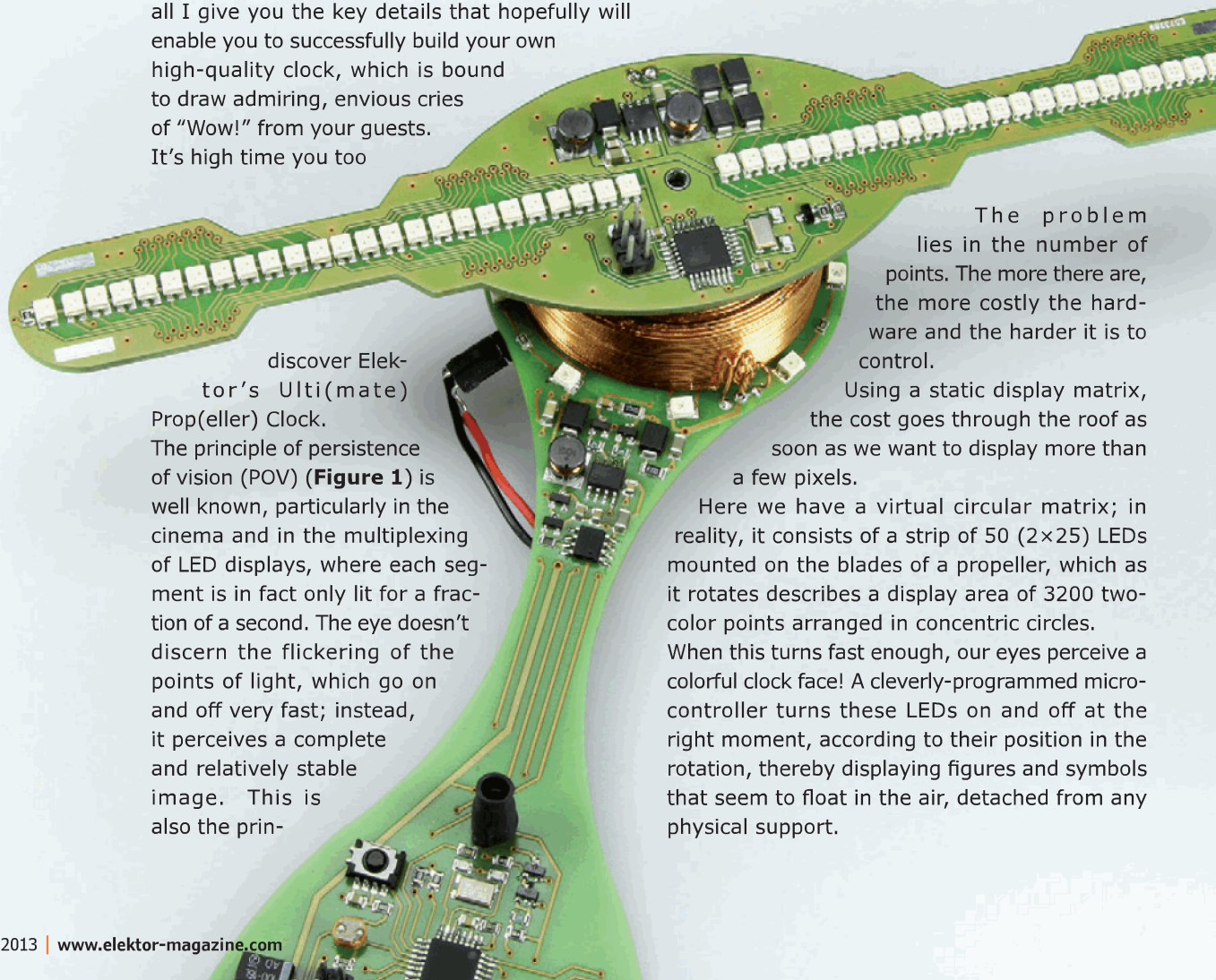

discover Elektor's Ulti(mate) Prop(eller) Clock. The principle of persistence of vision (POV) (**Figure 1**) is well known, particularly in the cinema and in the multiplexing of LED displays, where each segment is in fact only lit for a fraction of a second. The eye doesn't discern the flickering of the points of light, which go on and off very fast; instead, it perceives a complete and relatively stable image. This is also the prin-

The problem lies in the number of points. The more there are, the more costly the hardware and the harder it is to control.

Using a static display matrix, the cost goes through the roof as soon as we want to display more than a few pixels.

Here we have a virtual circular matrix; in reality, it consists of a strip of 50 (2×25) LEDs mounted on the blades of a propeller, which as it rotates describes a display area of 3200 two-color points arranged in concentric circles. When this turns fast enough, our eyes perceive a colorful clock face! A cleverly-programmed microcontroller turns these LEDs on and off at the right moment, according to their position in the rotation, thereby displaying figures and symbols that seem to float in the air, detached from any physical support.

That's easy to say

The idea is promising, but comes up against two electromechanical obstacles which gave me quite a headache: first, powering the LEDs on the propeller; and then the communication with the propeller microcontroller. No question of fitting a battery—it wouldn't last long. No question either of using slip-rings or brushes. Those would wear out quickly and be noisy. To transfer the power without contact, I chose to make use of the magic of electricity, by way of induction in a **custom-built transformer**.

The choice of the propeller motor is crucial, as it needs to be silent, fast, easy to source everywhere, and with as long a life as possible. Obviously, the ordinary old carbon-brush motor won't do. Inaudible and hard-wearing, a magnificent brushless motor out of a hard disk drive would have been very tempting, but its metal body proved incompatible with the induction process. So I fell back on a computer fan motor—easy to source, reliable and quiet, sufficiently powerful, and made of plastic.

There now remains the thorny question of the user interface. The control elements, their management and that of most of the functions are on a stationary base unit; on the propeller, I only fit the strict necessary for lighting the LEDs. In this way, I reduce the masses involved, particularly to avoid vibration, noise, and wear. To communicate without wires between the base and propeller, I've designed an infrared link using a fixed ring of emitters, above which rotates a photo-detector fitted to the propeller. After a great deal of trial and error and several generations of prototypes, all this ended up giving the circuit, the block diagram of which is given in **Figure 2**. The two most important components in this project are, in the center of the diagram: transformer Tr1, along with the motor M on which it is wound; Tr1 is what powers the propeller LEDs and their drive circuit. You won't find either of these components in either the base unit or propeller circuit diagrams, but we're going to be talking a lot about them.

Magic propeller

I'm going to start with the propeller, as this is doubtless the part that's intriguing you the most. The algorithm for obtaining this image that seems to float without any physical sup-

port is simple. The propeller determines its own angular position thanks to a phototransistor at the end of one of its blades, illuminated at each rotation as it passes in front of an infrared LED on the fixed unit. In this way, the microcontroller receives one short pulse every rotation. An internal counter measures the time between two pulses, i.e. the duration of a revolution. The value read is divided by 128, which corresponds to the number of 'spokes' making up the circular image. This result is then entered into a second counter, which will interrupt the running of the program 128 times per rotation. A matrix of 128 bytes, where each bit represents the state of one LED, is then scanned and the value it contains converted into a light code.

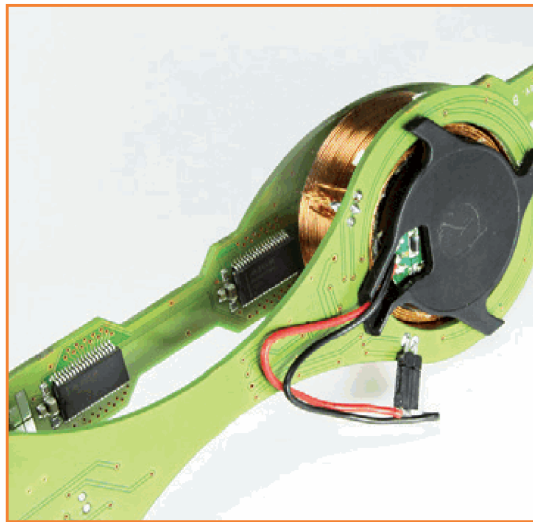

So much for the theory. Simple, isn't it? Everything is handled in a few lines in the interrupts in such a way as to make only modest demands on the processor resources. Thanks to this constant measurement of the actual duration of a revolution, the display remains spectacularly stable whatever the rotational speed.

In practice, it's a little bit more complicated, for three reasons. Firstly, since each column has two colors and is formed from 25 LEDs (**Figure 3a**), so the matrix consists of 768 bytes rather than 128. Secondly, to improve the stability of the display, the processor anticipates the duration of the current revolution by deducing the acceleration of the propeller by comparing the duration of the two preceding rotations. Thirdly, experimentation had taught me that to avoid the dis-



Figure 1. Images of the clock obtained through persistence of vision (POV).

Ten points to the circuit

1. The clock includes two ATmega 328 microcontrollers, one fitted in a fixed base unit and the other on the two-bladed propeller.
2. The propeller microcontroller drives 2×25 LEDs, employing persistence of vision to display a circular image made up of 3200 points.
3. The propeller is glued to the hub of a fan motor and turns with it.
4. The stator of this same motor is glued to the base unit.
5. The electrical energy is transferred without wires from the base to the propeller via a transformer with two concentric windings, wound around the motor, whose fan blades have been cut off.
6. The transformer primary (outer winding) is glued to the base. The secondary (inner winding) is glued to the motor hub.
7. The display control data are sent to the propeller microcontroller by means of an infrared signal emitted by a ring of emitters on the base, above which turns a photodiode.
8. The propeller is virtually inaudible, as it spins relatively slowly, the image obtained through persistence of vision is stable, on the one hand because the two blades take it in turns to produce the same fragment, and on the other, because the microcontroller adapts it to the actual rotational speed of the propeller.
9. Virtually all of the tasks are handled by four interrupts.
10. A single rotary encoder with push-button on the base unit is used to perform all the settings: standby, time and date setting, brightness and daytime and night-time rotational speed, language selection, and display mode selection (61 possible configurations!)

play's flickering, it needed a fairly high speed; now higher speed means more noise. So I use a double refresh: each half of the propeller emits the same light signals as its counterpart, but with a delay of half a rotation, i.e. 64 spokes. The more stable display thus obtained is even more pleasant to the eye, even at a fairly low speed of the order of 1500 rpm. At this speed, the propeller is almost inaudible! The biggest task the propeller microcontroller has to handle is filling our matrix of points, the

data of which are never fixed.

So it has to decode the sequences received on its serial port over the infrared link and fill this display table with one of the two built-in typefaces (5×7 and 6×10 pixels). It also has to handle the flipping of the characters, depending on whether they are in the top or bottom semi-circle of the disk. The microcontroller also drives the luminous power and draws the hands of the clock in analog mode, along with the seconds count around the perimeter (Figure 1).

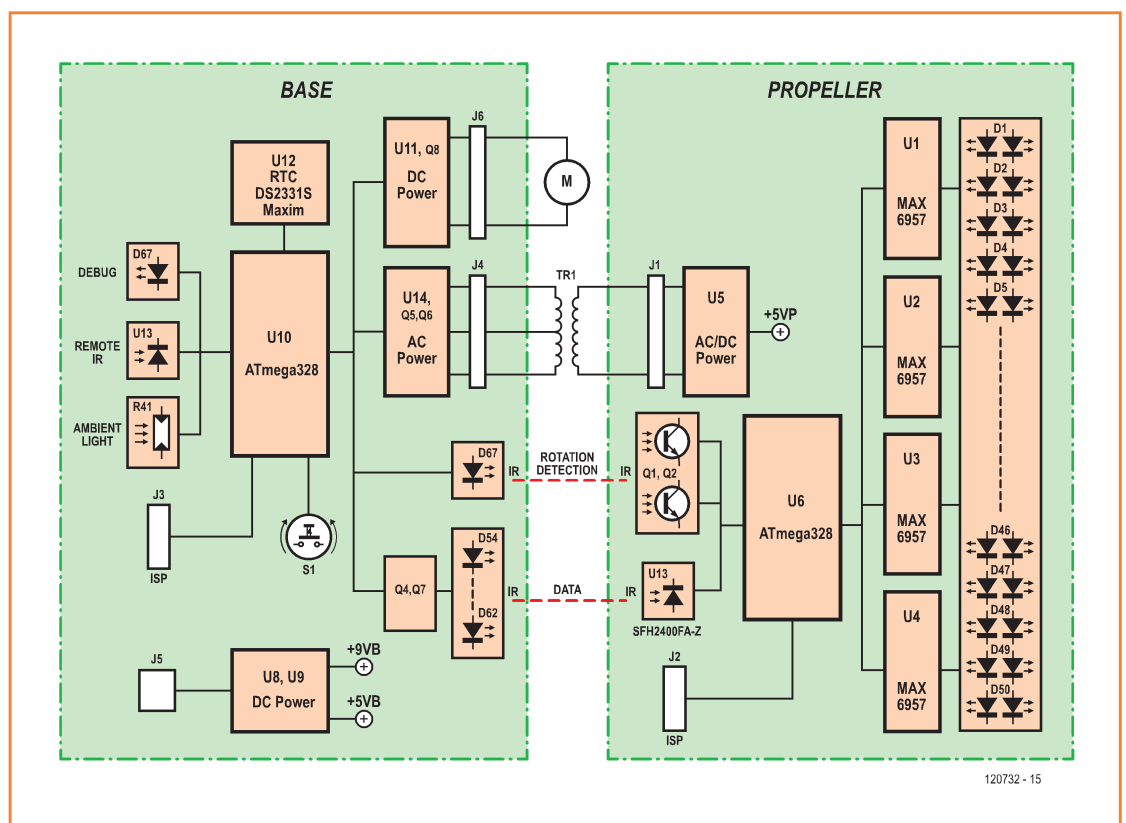
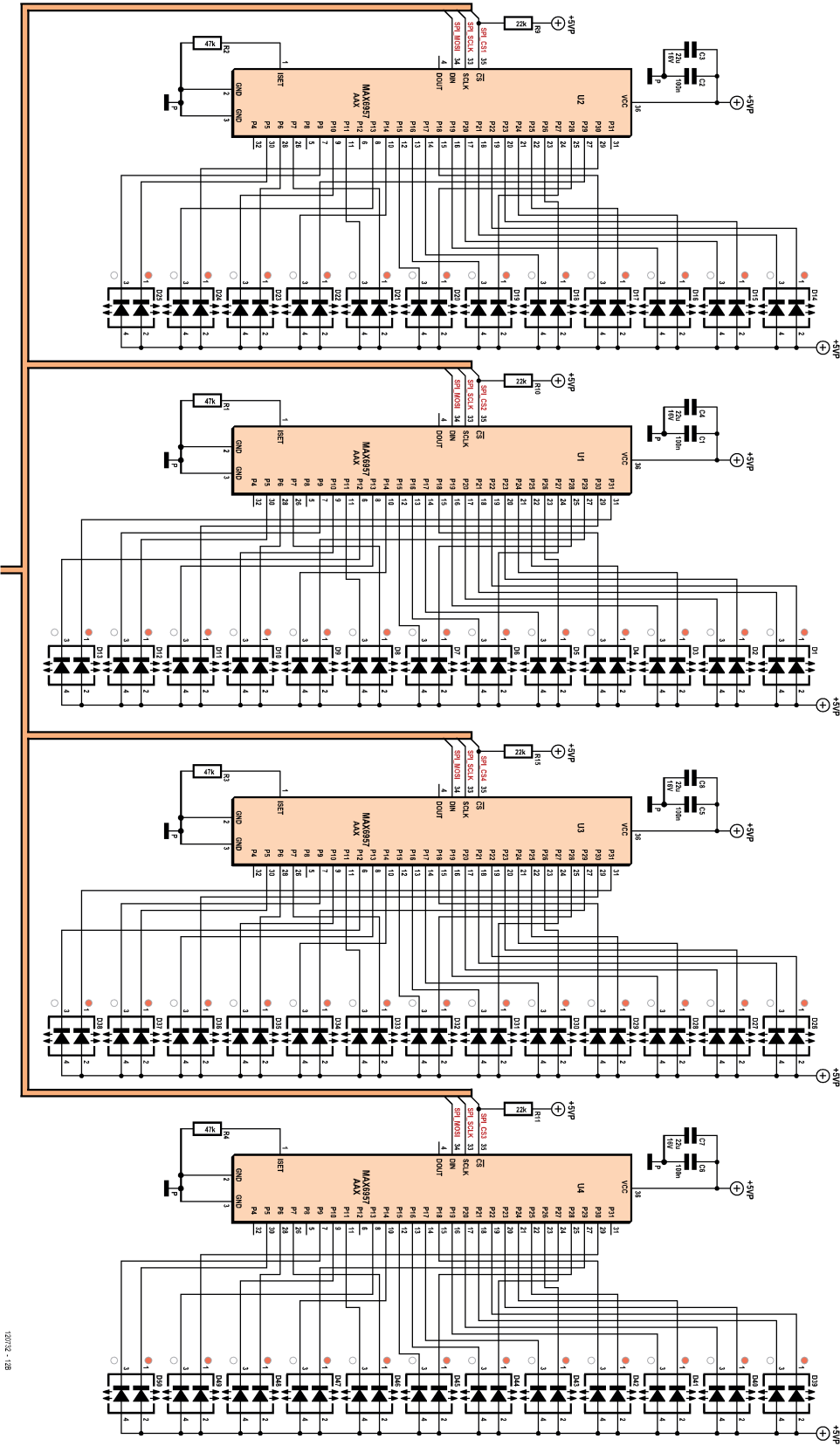

Figure 2. Block diagram of the clock in two PCBs—the base unit and the propeller. Between these, three essential mechanisms: the motor, the transformer, and the invisible but indispensable infrared radiation.



120712 - 11B

Figure 3a.
The most visible half of the propeller circuit diagram: 50 two-color LEDs and their four drivers.

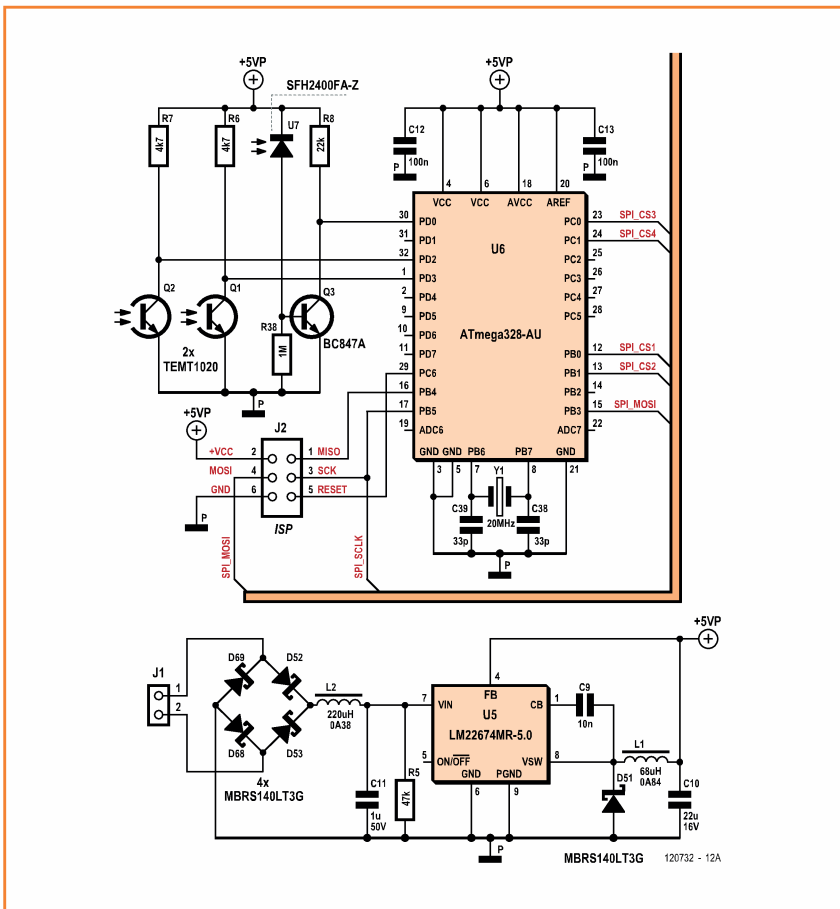
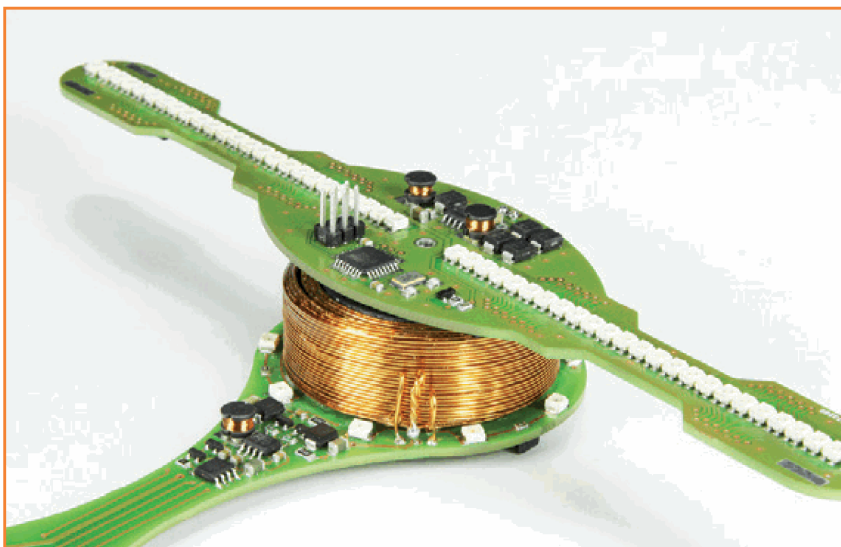

Figure 3b.

The active half of the propeller circuit diagram: the power supply, the microcontroller, and the photo-detectors.

UltiProp circuit

The 25 LEDs per propeller blade make it possible to display three lines of 8-pixel high characters. The last one draws the seconds display on the outer circle. I've chose red and white



two-color LEDs. The MAX6957 ICs use constant current drive, so the rated working voltage of these LEDs is unimportant. So you'll be able to choose other types, with the colors you like, as long as the pin-outs are compatible. The drive ICs U1–U4 are very handy, they drive up to 28 outputs each with the help of a simple SPI (Serial Peripheral Interface) link. The current for each output can be adjusted up to 20 mA via the bus, which is perfect for controlling the overall brightness. With modern high-brightness LED's (over 100 mcd), the power is more than enough for indoor use.

I chose the ATmega328 microcontroller (**Figure 3b**) above all because it has at least 1 KB of RAM for storing the display matrix. It is clocked at 20 MHz to offer as fast as possible an SPI link, needed for refreshing the LEDs.

So that the infrared link between base and propeller is maintained throughout the entire 360° rotation of the propeller, I've chosen a fast wide-angle photodiode (SFH2400). The FA version of this device also offers visible light filtering, which can't do any harm. Illuminated by an infrared light source, this diode delivers a current of a few microamps, which is amplified and inverted by Q3 to make the output level directly compatible with the Rx input on the USART U6.

The angular position of the propeller is given by phototransistors Q1 and Q2 located at the end of each blade each time they pass in front of a fixed LED.

The propeller supply voltage is taken from the secondary of transformer Tr1 (we'll come back to this later) via J1, rectified by the four diode D52, D53, D68, and D69, and filtered by L2 and C11. Off load, the voltage here is of the order of 15 V, dropped to 5 V by U5 and its associated components.

Before leaving the propeller to describe the base unit circuit, just a little more about the...

UltiProp software

The functioning of the software becomes simple once you have grasped the principle of the floating display. After a phase of initialization of the peripherals (internal and SPI), the code goes into wait. Everything is handled by four interrupts. When a serial sequence is received, the software stores the bytes received, decodes them, and

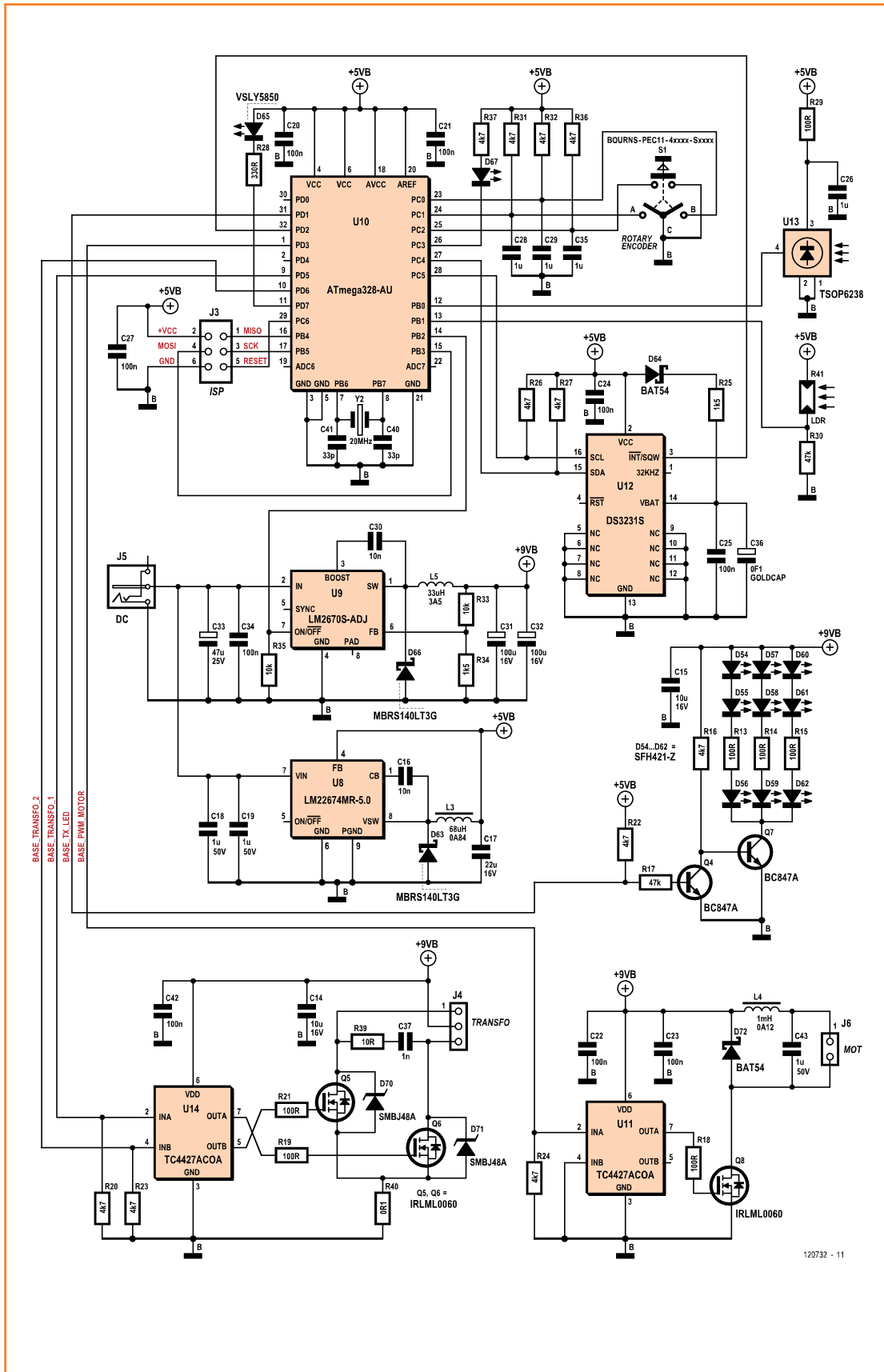

Figure 4. Base unit circuit diagram. The motor and transformer are shown only in Figure 2.

Listing 1 - Protocol for communication between base unit and propeller

Command : [DISPLAY_TYPE] : 0x00

Data : [ANA/NUM, DATEEN, TEMPEN, MDCOL, MDEN, SECCOL, SECRNG1, SECRNG0] :

- ANANUM : Display format [0: Analog, 1: Numeric]
- DATEEN : Display date [0: Disabled, 1: Enabled]
- TEMPEN : Display temperature [0: Disabled, 1: Enabled]
- MDCOL : Minutes dots color [0: Color 1, 1: Color 2]
- MDEN : Display minutes dots [0: Disabled, 1: Enabled]
- SECCOL : Seconds ring color [0: Color 1, 1: Color 2]
- SECRNG : Seconds ring type [00: Disabled, 01: Elapsed Seconds, 10: Full ring, 11: Fixed ring]

Command : [LUM_POWER] : 0x01

Data : [UNUSED, UNUSED, UNUSED, UNUSED, LUMPWR3, LUMPWR2, LUMPWR1, LUMPWR0]

- UNUSED : Unused [0000]
- LUMPWR : Luminous Intensity [0000: Minimum to 1111: Full power]

Command : [TIME] : 0x02

Data : [HMCOL, UNUSED, UNUSED, HOURS4, HOURS3, HOURS2, HOURS1, HOURS0]

- HMCOL : Hands color (Analog mode), Hours text color (numeric mode) [0: Color 1, 1: Color 2]
- UNUSED : Unused [00]
- HOURS : Current hour [0x00 to 0x17]

[UNUSED, UNUSED, MINUT5, MINUT4, MINUT3, MINUT2, MINUT1, MINUT0]

- UNUSED : Unused [00]
- MINUT : Current minute [0x00 to 0x3B]

[UNUSED, UNUSED, SECON5, SECON4, SECON3, SECON2, SECON1, SECON0]

- UNUSED : Unused [00]
- SECON : Current second [0x00 to 0x3B]

Command : [DATE] : 0x03

Data : [DATCOL, UNUSED, LANG1, LANG0, MONTH3, MONTH2, MONTH1, MONTH0]

- DATCOL : Date text color [0: Color 1, 1: Color 2]
- UNUSED : Unused [0]
- LANG : Display language [00: Eng, 01: Fr, 10: Ger, 11: Undefined]
- MONTH : Current month [0x00 to 0x0B]

[DAYWK2, DAYWK1, DAYWK0, DATE4, DATE3, DATE2, DATE1, DATE0]

- DAYWK : Day of week [000: Monday to 110: Sunday]
- DATE : Current date [0x00 to 0x1E]

Command : [TEMPERATURE] : 0x04

Data : [TEMPCOL, UNUSED, TEMP6, TEMP5, TEMP4, TEMP3, TEMP2, TEMP1]

- TEMPCOL : Temperature text color [0: Color 1, 1: Color 2]
- UNUSED : Unused [0]
- TEMP : Integer portion of temperature

[TEMPFRAC1, TEMPFRAC0, UNUSED, UNUSED, UNUSED, UNUSED, UNUSED, UNUSED]

- TEMPFRAC: Fractional portion of temperature
- UNUSED : Unused [000000]

Command : [DISPLAY_TEXT] : 0x05

Data : [TXTCOL, TXTCLR, TXTSIZE, UNUSED, UNUSED, UNUSED, SECT1, SECT0]

- TXTCOL : Text color [0: Color 1, 1: Color 2]
- TXTCLR : Clear sector prior to write new data [0: Keep previous text, 1: Clear then write]
- TXTSIZE : Text font [0: FONT_6x7, 1: FONT_8x16]
- UNUSED : Unused [000]
- SECT : Sector number [0x00 to 0x03]

[UNUSED, TXT6, TXT5, TXT4, TXT3, TXT2, TXT1, TXT0]

- UNUSED : Unused [0]
- TXT : ASCII Character to display [0x30 to 0x3A, 0x41 to 0x5A, 0x61 to 0x7A]

[TXT]

- Max 10 ASCII Characters in FONT_6x7 or 8 chars in FONT_8x16

Command : [TEST_FRAME] : 0x06

No Data

Command : [CHRISTMAS_TREE] : 0x07

Data : [UNUSED, UNUSED, UNUSED, UNUSED, UNUSED, UNUSED, UNUSED, TREEEN]

- UNUSED : Unused [00000000]
- TREEEN : Christmas Tree [0: Disabled, 1: Enabled]

performs the corresponding actions (filling the matrix with new values, updating the time, or driving the overall LED current). During an external interrupt triggered via Q1 or Q2, the value in counter 1 is read—this corresponds to the duration of a revolution. Divided by 128, this value is injected into counter 0 and the display pointer is reinitialized. If the counter reaches maximum without having been reset, the rotational speed is too low, and so the drive to the LEDs is disabled. Otherwise, during the periodic interrupt triggered by counter 0 (hence 128 times per revolution) the display matrix pointer is incremented, and the corresponding value is sent to the LED drive circuits. If the time is being displayed in analog mode, the software also handles the lighting up of the hands and the seconds count at this instant (see Listing 2 with the pseudo-code for the propeller).

Powering

The fundamental function of the base unit (Figure 4) is to provide the power to the propeller. The custom-wound transformer around the motor hub is concentric with the axis of rotation. The primary, wound on the outside, is fixed to the base and so doesn't move. The secondary, with a slightly smaller diameter, is positioned in the center of the primary, around the motor, and so turns with the propeller. The alternating voltage applied to the primary of this transformer via U14, Q5, and Q6 induces a magnetic flux coaxial with the axis of rotation, which in turn induces an alternating voltage in the secondary. This transformer is wired in a push-pull configuration: the primary is divided into two halves, driven by Q5 and Q6, themselves driven alternately by a squarewave at a frequency of 50 kHz from counter 0 and outputs OC0A and OC0B of the microcontroller. Thanks to the transformer ratio of 1.73, we recover on the secondary a square-wave voltage between -15 and +15 V, rectified, smoothed, and regulated down to 5 V. The damping circuit R39 and C37, helped by 'transzorb' diodes (a sort of very fast zener diode) D70 and D71, limits voltage transients at the transistor terminals during switching. In order to guarantee clean switching on, the driver U14 provides the transistors with a current significantly higher than that of a simple microcontroller output. Inserted between the sources and ground, resistor R40 offers a point for examining an image of the current (Figure 5), whose triangular shape you will

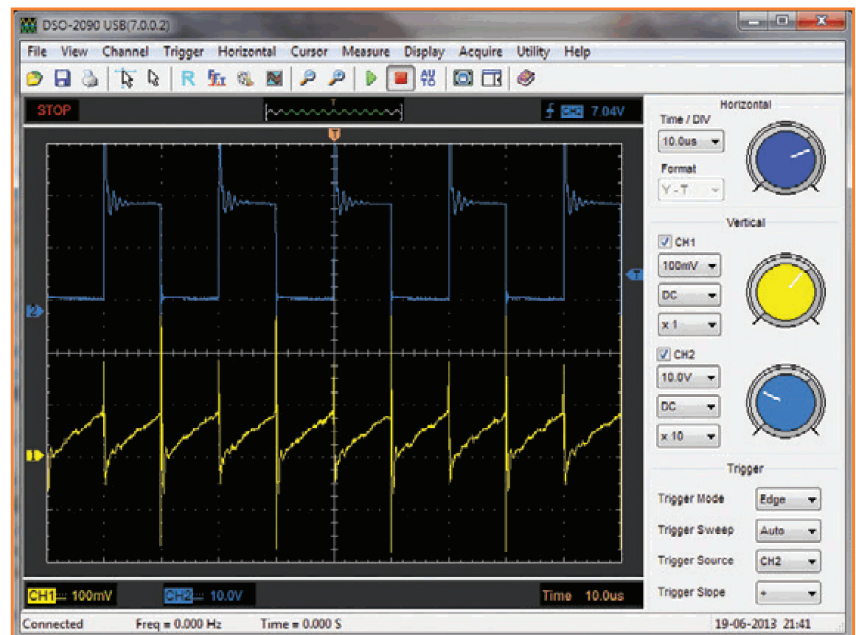

note. The amplitude reaches barely 100 mV, i.e. a bit less than 1 A. With this converter topology, there is always one of the transistors conducting at any moment. If this condition were to last, the current would increase indefinitely until 'burnt out'. So it is absolutely vital to avoid halting the program, e.g. by connecting a programming tool while it is running.

Figure 5. Voltage on one of the primaries (blue) of transformer TR1 and across R40 (yellow).

If however you wanted to venture into this experiment, make sure your probe is configured to leave the counters running even in pause, without which the first breakpoint could be fatal. This option is available under AVR Studio 4 or Atmel Studio 6, in the configuration menu of your debugging tool.

The propeller turns

Now we have the means to power the propeller, we need to make it turn fast enough to obtain the hoped-for effect. The power and speed developed by a PC fan motor are perfect for the mass to be moved. As for the noise, it is close to inaudible. All this for little money! The rotational speed control is achieved by means of another PWM output on U10 which, via the driver U11, switches transistor Q8, also at a frequency of 50 kHz. In association with D72, L4, and C43, we thus form a step-down switching power supply which, depending on the duty cycle of the PWM, supplies the motor with a voltage between 0 and 9 V. If you're familiar with this type of supply, you'll note the unusual

Listing 2 - Pseudo-code for the UltiProp Clock

```
void main(void)
{
  do
  {
    switch(stateMachine)
    {
      case INIT:
      {
        //Initialise variables, microcontroller's registers, interrupts, LED drivers, USART
        stateMachine = IDLE;
      }
      case IDLE:
      {
        //All time critical operations occur in external and timer interrupts
        //New serial frame received ?
        if (g_u8_frameReceived == 1)
          //Process incoming frame : Decode, fill new display matrix, update hands position
        }
      }
    }
  }
  while(1);
}

//Interrupt called once per revolution
#pragma vector = INT1_vect
__interrupt void MCU_Int1Interrupt(void)
{
  //Set column index for hand 0 at 32+64
  u8_columnIndexHand0 = 32;
  //read Timer 1 value
  u16_revolutionPeriod = TCNT1;
  //divide Timer 1 value by 128, and set Timer 0 period with this value
  OCR0A = (u8)((u16_revolutionPeriod >> 7)-1);
  //reset and enable timer 1
  MCU_EnableTimer1();
  //Update display variable
  MCU_UpdateColumn();
  //Update LED status
  LED_Update();
}

//Interrupt called 128 times per revolution
#pragma vector = TIMER0_COMPA_vect
__interrupt void MCU_ColumnInterrupt(void)
{
  //Increment index
  u8_columnIndexHand0++;
  //Update display variable
  MCU_UpdateColumn();
  //Update LED status
  LED_Update();
}

//This function updates display bytes from display matrix
void MCU_UpdateColumn(void)
{
  //Update display variable for hand 0
  g_currentColumn.hand0OuterWhite = g_u8_displayOuterWhite[u8_columnIndexHand0];
  g_currentColumn.hand0OuterRed = g_u8_displayOuterRed[u8_columnIndexHand0];
  g_currentColumn.hand0MiddleWhite = g_u8_displayMiddleWhite[u8_columnIndexHand0];
  g_currentColumn.hand0MiddleRed = g_u8_displayMiddleRed[u8_columnIndexHand0];
  g_currentColumn.hand0InnerWhite = g_u8_displayInnerWhite[u8_columnIndexHand0];
  g_currentColumn.hand0InnerRed = g_u8_displayInnerRed[u8_columnIndexHand0];
}
```

position of the transistor; referenced to ground in this way makes it easier to drive. However, the output is no longer directly at the negative voltage—but that’s no problem for us in this particular instance.

The propeller communicates

Now it turns, all that’s left to do is to transmit—without wires, of course—the information to be displayed to the propeller. The rotating part includes a photodiode to receive infrared signals, which sees a ring of nine wide emission angle infrared LEDs D54–D62, mounted on the base unit. These LEDs are all powered together and modulated simply according to the level present on the ATmega’s UART output. Q7 takes care of supplying the current needed to light them. Due to the inversion by Q4, the quiescent logic high on the Tx pin corresponds to the unlit state of the LEDs. The choice of fast diodes for emitting and receiving means we can ensure a data rate of 19,200 baud. At this speed the reliability of the communication is impressive.

Packetizing of the data transmitted offers better immunity to any brief interruptions to the communication channel. Each sequence starts with the ASCII code Data Link Escape DLE (0x10), followed by the STX Start of Text byte (0x02). Then come a maximum of 66 useful bytes. The packet sequence ends with another DLE byte followed by an ETX End of Text (0x03). Now it is possible that an 0x10 byte might occur within the useful data being transmitted. In order to avoid its being mistaken for the DLE code, the byte will be automatically sent twice and treated in parallel upon reception. Thus sequences of any length can be transmitted; the receiver sorts them out and only keeps complete sequences (**Figure 6**). The communication protocol for these bytes is specific to the propeller. The complete list of the commands available is given in **Listing 1**. Each sequence transmitted starts with the pair DLE/STX, then continues with a command byte between 0 and 5. The bytes following are the parameters for the command, whose length can vary. Lastly, the pair DLE/ETX ends the sequence and triggers processing of the data received. For displaying text, the display zone is divided into four sectors (**Figure 7**). Up to ten alphanumeric characters can be displayed in each zone in the smallest type size. A second set of characters, slightly larger, gives a maximum of eight symbols. In this case, only sectors zero and one

DLE	STX	'A'	'B'	'C'	'D'	'E'	DLE	ETX
0x10	0x02	0x41	0x42	0x43	0x44	0x45	0x10	0x03

are available. The software automatically handles the rotation of the bytes forming each symbol displayed, in which each bit corresponds to the lighting of a LED. Specifically, bit 0 corresponds to the lighting of a LED. When in the upper edge, there is no rotation of the bytes, and bit 0 (i.e. top edge of symbols) is on the exterior circle. By contrast, in the lower semicircle the rotation is required to place bit 0 (i.e. top edge of symbols) on the inner circle.

Microcontroller and peripherals

Just like for the propeller, the base unit microcontroller is an ATmega328. Two thirds of its 32 kB program memory are free (for future applications...). In order to adjust the display brightness, the ambient light level is sensed by LDR R41. The infrared LED D65 is a narrow-angle type, as it is used as a position detector for the propeller. Turning this LED off immediately disables the propeller display. S1 is a rotary encoder with built-in push-button which handles the whole man/machine interface, including the configuration menu and the adjustments to the settings. D67 is a simple orange LED used for perfecting the program. You can leave it out if its flashing every second bothers you.

The Maxim DS3232 real time clock (U12) calculates the time and date, with a maximum drift of 2 ppm, or around a mere 30 seconds a year,

Figure 6. Example of packetizing of a sequence “ABCDE”.

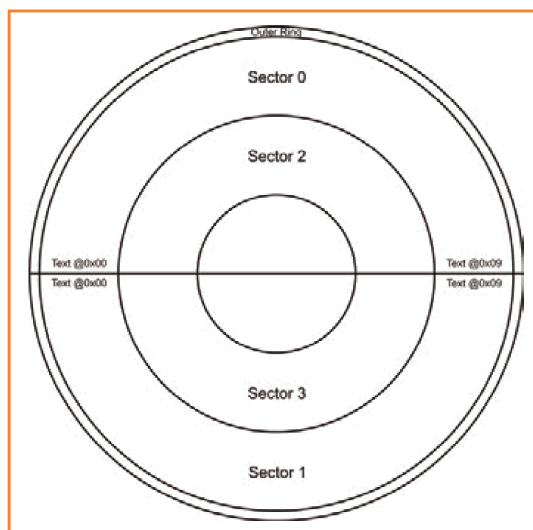

Figure 7. Display sectors.

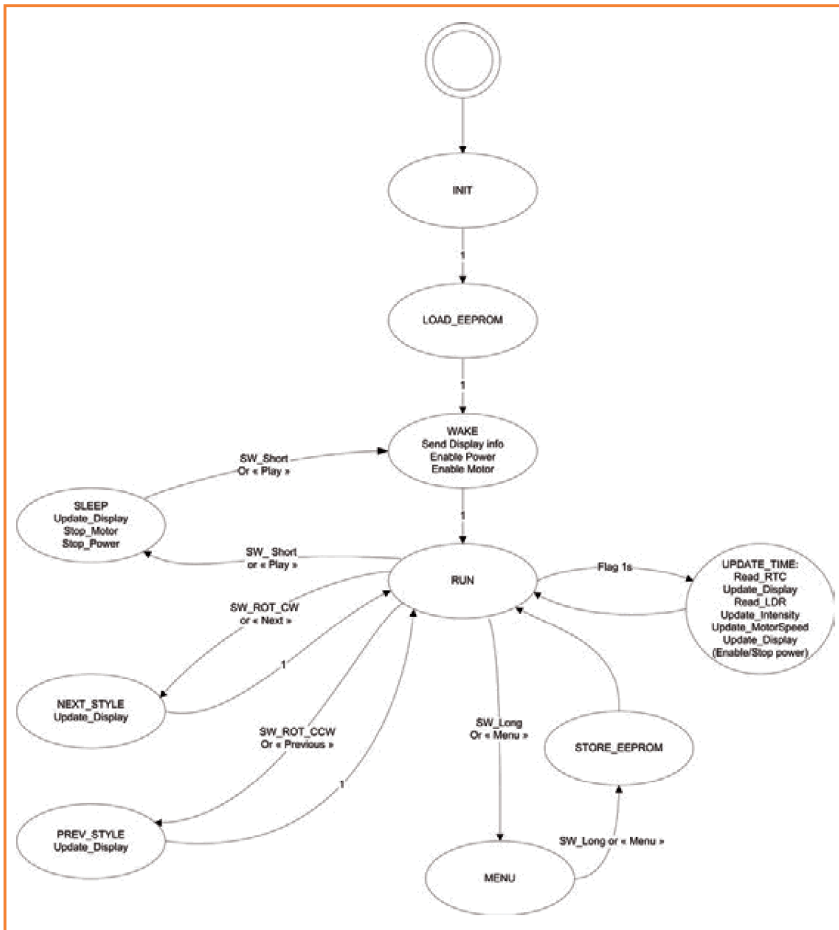

Figure 8. State machine for base unit software.

thanks to the thermal compensation of its built-in oscillator. In the absence of power, the internal counter will carry on running for several days thanks to the power supplied by the super-capacitor C36. When you turn the clock back on, it will have kept time.

The base unit power supply is in two parts, a 5 V one of just a few milliamps for the logic part, and a second more powerful 9 V one for powering the transformer, motor, and infrared LEDs. This power section can be shut down to save power consumption in standby.

Remote control

To add a little more magic to the operation of this clock, I've grafted on an infrared remote-control receiver (U13) which talks to the microcontroller via its Input Capture function. This receiver includes a demodulator for 38 kHz signals at a wavelength of 950 nm, but other types are available, so you can choose them to suit the transmitter you want to use. In my own case, I've used a nice white control originally intended to control

Apple MP3 players [3]. With its simple six-key interface, it is ideal for controlling our clock. On this transmitter, the data are sent under the NEC protocol, which defines a '0' bit by the transmission of a burst @ 38 kHz for 562 μs followed by a blank of the same duration. The logic '1' is coded using the same transmission time, followed by a triple-length blank, i.e. 1.62 ms. Each press on one of the keys causes four bytes to be sent, the first two of which identify the remote-control, while the last two indicate the key pressed.

Base unit software

The state machine in Figure 8 gives an idea of the overall operation of the base unit software. Using counters 0 and 2 to produce the power control signals and with counter 1 dedicated to decoding the remote-control sequences, I found myself short of clocks for timing the program. So to control an interrupt input, I used the 1.024 kHz signal from U12. With each second that passes, the real time clock is read and its value sent to the propeller. The system takes advantage of this to check the ambient light level (weighted over five measurements) and adjust the display brightness if necessary. The rotary encoder is also handled via an interrupt, not without a software de-bounce filter.

Tempus fugit (time flies)

The moment has come to hit Pause. I hope I've whetted your appetite and invite you to join me again in the next issue of Elektor, where I'll be talking about building my UltiProp Clock. To lessen the frustration this *tempus interruptus* may cause you, the PCB designs for the project are released with this installment. I am also planning to put a selection of the available documentation on the article's page on the Elektor website [1, 2]. I'm sure you can wait a few weeks—I've been perfecting this project for over six years!

(120732)

Internet Links

- [1] 120732 – Propeller Clock – Montage.pdf
- [2] Downloadable software, including ATmega source code: www.elektor.com/120732
- [3] Remote-control for Apple Universal Dock: <http://store.apple.com/us/product/MC746LL/A/apple-universal-dock?fnode=72>

One platform for 8-, 16- and 32-bit development - with Microchip's MPLAB® X IDE

8-bit PIC®
Microcontrollers
128K Flash
16 MIPS
250+ Options

16-bit PIC®
Microcontrollers &
dsPIC® Digital Signal
Controllers
256K Flash
70 MIPS
150+ Options

32-bit PIC®
Microcontrollers
512K Flash
1.5 DMIPS/MHz
80 MHz

MPLAB® X Common
Integrated Development Environment

500+ complementary
Analog & Memory solutions

MPLAB X
Integrated Development Environment

• Open-Source • Cross-Platform • Universal

MPLAB® X IDE is the free, integrated toolset for all of Microchip's 900+ 8-, 16- and 32-bit PIC® Microcontrollers, dsPIC® Digital Signal Controllers, and memory devices. Based on the open-source NetBeans platform, MPLAB X runs on Windows® OS, MAC® OS and Linux, supports many third-party tools, and is compatible with many NetBeans plug-ins.

MPLAB XC compilers help increase code speed of any PIC® Microcontroller or dsPIC® digital signal controller by 30%, whilst also cutting code size by 35%. These new compilers give designers the choice of Free, Standard or Pro code optimisation levels for 8-bit, 16- or 32-bit development, or a single C compiler suite to support all Microchip Microcontrollers and digital signal controllers.

Microchip's tool chain of compatible compilers and debugger/programmers operate seamlessly within the universal, cross platform open-source MPLAB® X integrated development environment, reducing both learning curves and tool investments.



START DEVELOPING TODAY

Download a free copy of MPLAB X and choose from a choice of new C compilers:

- MPLAB XC8 for 8-bit MCUs
- MPLAB XC16 for 16-bit MCUs and DSCs
- MPLAB XC32 for 32-bit MCUs
- MPLAB XC Suite for all 900+ PIC MCUs and dsPIC DSCs.

Evaluate MPLAB X today! www.microchip.com/get/eumplabx



Microcontrollers • Digital Signal Controllers • Analog • Memory • Wireless

Multi I/O for FPGA Development Board (1)

Add a display, sensors, GPS, pushbuttons, LEDs and more

Features

- GPS receiver
- Temperature sensor
- Pressure sensor
- RGB color sensor
- 2 x 16 character LCD
- 4 Pushbuttons
- 4 LEDs
- Rotary encoder
- 7 external digital expansion pins
- 3 external analog inputs

By **Andreas Mokroß, Dominik Riepl, Christian Winkler** and **Professor Thomas Fuhrmann** (Germany)

Back in December 2012 in an article titled 'Taming the Beast' we introduced you to our FPGA development board. The board offers speed and convenience to the task of integrating a programmable logic chip into a project design. It already has a host of interconnect possibilities but, up till now, no integrated peripherals. Enter the expansion board...

The FPGA development board is a useful tool for both professional and amateur use. Its practical layout makes it easy to incorporate into a design or to use as a teaching aid for University students. As part of a student project at the Ostbayerische Technische Hochschule (OTH) Regensburg in Germany an expansion board was developed containing a host of peripheral devices. Now the FPGA development board has sensors to talk to and we can interface with them using VHDL.

The board concept

Figure 1 shows the expansion board block diagram. Peripheral components all connect to the FPGA. The simpler peripherals such as pushbuttons and the rotary encoder connect directly to FPGA I/O pins and require no specialized protocol to communicate. The LCD, GPS-module and A/D converter all transfer data and commands using a digital serial interface following their own protocol. Seven unused pins from the FPGA development board are available at a connector for general I/O use.

The sensors with analog output signals are connected to the eight multiplexed inputs of an A/D converter. An RGB color sensor uses three inputs; one for red, one for green and one for blue.

Another two inputs are used by a pressure sensor and a temperature sensor. The remaining three unassigned analog inputs are taken to a connector to allow the measurement of external analog signals.

Note: we use both the FPGA chip pin numbers and the Elektor FPGA board pin numbers in this text.

Expansion Board + FPGA Development Board

The circuit diagram of the expansion board without the power adapter is shown **Figure 2**. The FPGA development board connects to the expansion board using two strips of socket headers. Connections on the expansion board have been grouped together along these strips according to the peripherals in order to simplify the layout and make debugging easier. The first part of the labels used to describe each signal refers to the module or component name. Next is the description of its function followed by a number.

Digital I/Os

Unused I/O pins from the FPGA development board are available at the 10-way pinheader JP4.

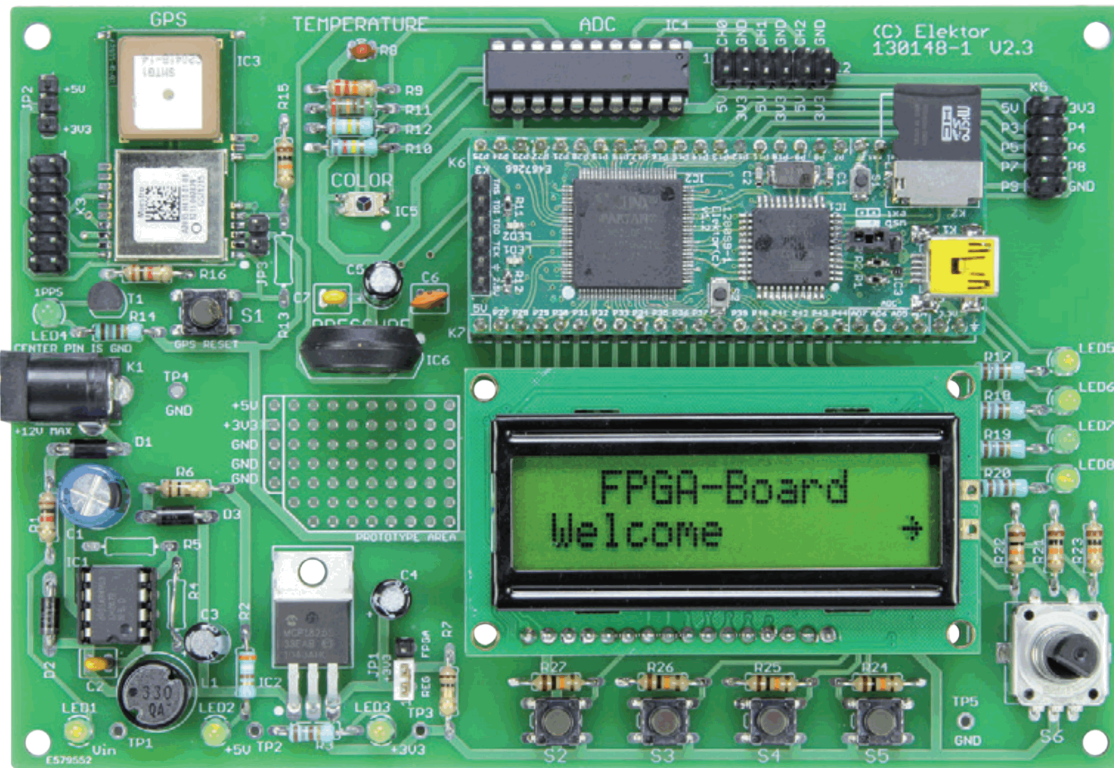

The header also provides connection to 5 V at pin 1, 3.3 V at pin 2 and ground at pin 10. The FPGA pins 48, 49, 53, 54, 57, 58 and 60 available at this connector are not provided with any form of protective circuit so be careful during experimentation when applying a voltage to any of these pins. The maximum input voltage range allowed on the I/O pins is 0.5 V above the FPGA's supply voltage and ± 0.5 V. The pins are also not protected against ESD so ensure that the board is used and stored in an electrostatically neutral environment.

The basic input and output options using LEDs, pushbuttons, rotary encoders are integrated into

the expansion board design. Using the hardware description language VHDL it is relatively simple job to interface with them and test their operation.

LEDs

The board contains four (LED5 to LED8) general purpose green LEDs which can be controlled via VHDL from the FPGA. They use standard thru-hole leads with the anodes connected to 3.3 V supply via 180 Ω resistors and their cathodes to the FPGA output pins. The resistor value chosen gives a current of approximately 5 mA through the LEDs. They are bright and visible but not dazzling.

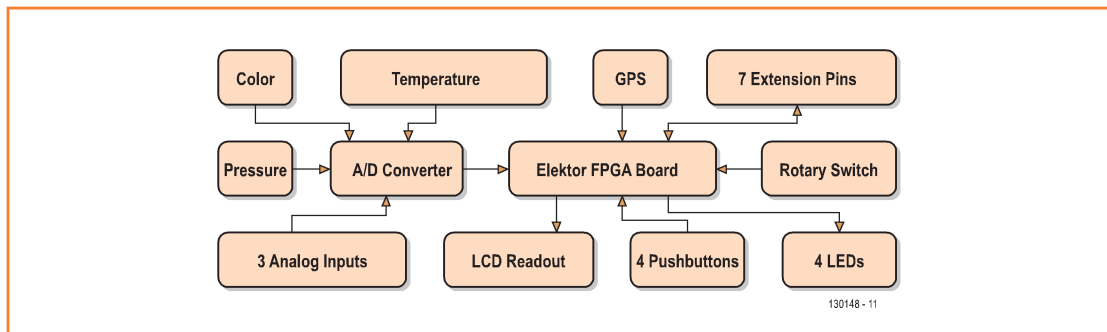

Figure 1. The block diagram.

The LEDs are connected so that they light when the corresponding FPGA output is Low (logic '0') i.e. they are 'active-Low'. A High output from the FPGA pin turns the LED off. They connect to pins 14, 15, 16 and 44 of the FPGA board which corresponds to pins 24, 61, 62 and 65 of the FPGA chips.

Pushbuttons and rotary encoder

Four pushbuttons are provided for manual input. They are positioned beneath the LCD so they can be easily associated with displayed menu options and can be used without obscuring the

LCD with your hand. The pushbutton and rotary encoder inputs have 10 kΩ pull down resistors fitted. The input signal state from these switches will therefore be logic '0' if the buttons are not pressed and '1' when pressed. The four push-buttons connect to pins 13, 15, 16 and 17 on the FPGA.

The rotary encoder S6 gives 24 pulses per revolution. Its two outputs provide a 2-bit incremental Gray-code signal connected to pins 18 and 23 of the FPGA. The rotary shaft also functions as a pushbutton switch. Pressing the shaft puts a logic '1' on input pin 22 of the FPGA.

Figure 2. The circuit diagram.

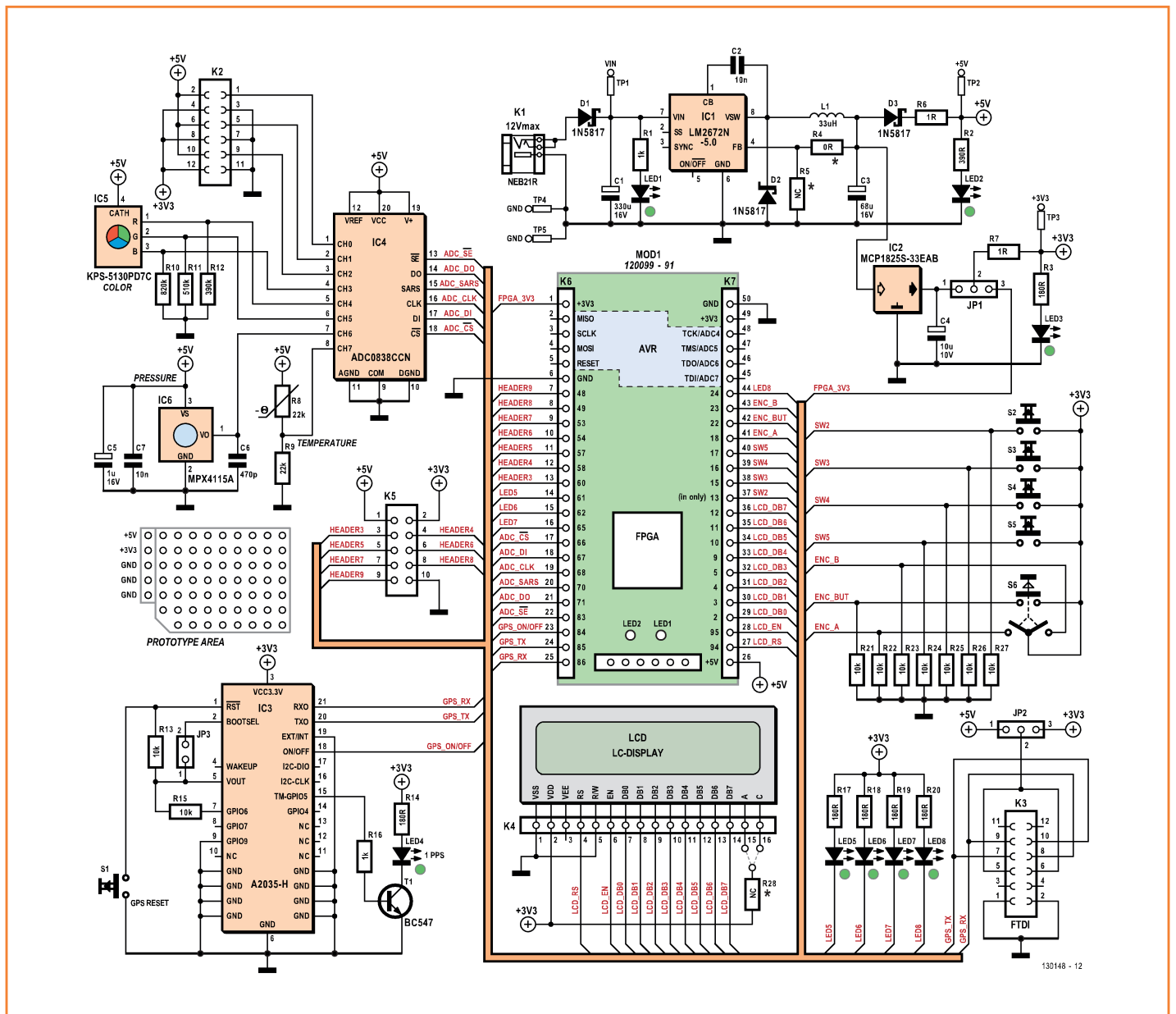

Display

During the concept phase of the expansion board's development we looked at the pros and cons of the different types of display available. For simplicity and cost we settled on the relatively basic black/white text display rather than a more complex graphic display. The controller built into this type of display also stores the displayed characters so it's only necessary to send character codes to the display.

Based on these criteria the project group chose the standard monochrome alphanumeric display consisting of two lines of 16 characters which has an on-board controller compatible with the Hitachi HD44780. It doesn't require any complex control protocol and works directly with ASCII character codes.

The display is positioned below the FPGA development board just above the row of input push-buttons. This gives the possibility of displaying characters or symbols directly above the push-button they refer to. The display plugs in to the expansion board and can be easily removed or swapped as necessary.

The display connects directly to pins on the FPGA: Register Select (RS) connects to pin 94 of the FPGA.

Enable (EN) connects to pin 95 of the FPGA.

The 8-bit data bus connects to pins 2 to 5 and 9 to 12 of the FPGA.

The LCD specified here doesn't have a backlight. You can use a compatible display with a backlight, in this case it will be necessary to fit resistor R28 and a short length of wire. The short wire jumper connects +3.3 V from K4 to either pin 15 or 16 via resistor R28. Whichever pin is used (depending on the backlight LED polarity); the remaining pin (pin 16 or 15 on K4) must be connected to ground with a wire link to complete the backlight circuit.

The A/D converter

The sensors fitted to the expansion board can be used to measure environmental variables. They have analog output signals which require conversion to digital values before they can be used by the FPGA.

IC4 is a Texas Instruments AD0838CCN A/D converter. This device is packaged in a DIP20 outline and has a serial data output, providing digital measurements with an 8-bit resolution. The

conversion process uses successive approximation. Each bit from the successive approximation comparator appears at the output irrespective of the selection control SE. After eight clocks the conversion is complete. Depending on the status of the control input SE the value will be output again, this time LSB first, at Data Out.

Conversion time is 32 μ s/S, which gives a maximum sampling rate of 32 kS/s. The IC is powered from the 5 V supply and has eight analog inputs which can be used to measure single-ended inputs referenced to ground or in pairs as differential inputs. A configuration command is sent to the converter to start conversion. The digital value is then sent as a serial data stream to the FPGA synchronized to the clock generated by the FPGA. The clock signal comes from pin 68 of the FPGA and must have a value between 10 kHz and 400 kHz. Each rising clock edge is used to read the serial control data to the controller. The converter uses each falling edge of the clock to output the next data bit. The FPGA uses the rising clock edge to read the value of this new bit.

A/D converter connections to the FPGA:

- Chip Select: FPGA-Pin 66.
- Data In: FPGA-Pin 67.
- SAR STATUS: FPGA-Pin 70.
- SE: FPGA-Pin 83.
- Data Out: FPGA-Pin 71.

Pressure sensor

IC6 is an atmospheric pressure sensor type MPX4115A from Freescale Semiconductor. It is powered from 5 V and produces an output voltage dependant of air pressure in the range of approximately 0.25 V to 4.75 V at room temperature (25 °C). As pressure increases the output voltage increases and the A/D converter digitizes this value and supplies it to the FPGA. An output level of 0.25 V corresponds to an air pressure of <15 kPa while 4.75 V >115 kPa.

The output voltage can be described using the transfer function:

$$V_{\text{out}} = V_{\text{in}} \times (0.009 \times P - 0.095) \pm (\text{Error} \times \text{Temperature factor} \times 0.009 \times V_{\text{in}})$$

where

$$V_{\text{in}} = 5 \text{ V} \pm 0.25 \text{ V}; P = \text{Pressure in kilopascal}; \text{Error} = \pm 1.5 \text{ kPa}$$

RGB Sensor

The RGB sensor type KPS-5130PD7C from Kingbright (IC5) is useful for measuring the brightness and sensing color. It uses three photo diodes with integrated red, green and blue color filters. In operation the photo diodes are reverse biased. The so-called photo effect causes light (photons) incident on the PN junction to liberate free charge carriers which produce a current. The dark current of the photodiodes is very low. The reverse current increases in proportion to the level of illumination. The resulting current passes through a resistor to ground. The voltage produced across the resistor can then be measured by the A/D converter.

The output voltage characteristic approximates very closely to a proportional relationship with illumination level. Using the voltage output values obtained from the three photodiodes it is now possible to calculate the illumination color. Sensitivity of the photodiode is to some extent

dependant on its output load resistance. The larger its value, the higher will be the voltage measured at a given light level. The diodes can be driven into saturation even at low levels of illumination. The sensitivity of each of the three photodiodes to filtered light is not identical. This is partly due to the light sensitivity/color response of the semiconductor material and also the filter properties. According to the data sheet:

- Red: 0.33 A/W
- Green: 0.25 A/W
- Blue: 0.18 A/W

Because of the different sensitivity of the photodiodes and the range of ambient light levels in different situations it may be necessary to change the value of the load resistors. The result of practical investigation in the lab yielded the following resistor values: R12 = 390 k Ω (red), R11 = 510 k Ω (green) and R10 = 820 k Ω (blue).

Temperature sensor

A standard NTC thermistor is used as a temperature sensor. Thermistors are available with different resistance ranges and have a high resistance gradient with respect to temperature change. Together with resistor R9 the thermistor forms a voltage divider network. The resulting voltage level is read by the A/D converter. The voltage measured across R9 is around 1 V at 0 °C and 3.75 V at 50 °C.

Analog expansion pins

Three inputs to the A/D converters are not used by any of the sensors. They are brought out from the board together with +5 V, +3.3 V supply and ground on connector K2. You can connect the outputs of additional analog sensors here or measure a voltage level. The digital value of the signal can then be used by the FPGA.

GPS

The GPS receiver module type A2035-H is from Maestro Wireless Solutions. It is based on the A2100-A GPS receiver with a built-in ceramic GPS patch antenna, so that no additional components are required. The receiver uses 48 parallel channels to evaluate the satellite data with high sensitivity. Working under ideal conditions it can resolve its position to within 2.5 m (8 feet). The GPS uses a serial UART interface to send positional data using the standard NMEA 0183

A GPS problem

We bought two GPS modules for the prototype we built here in the Elektor lab. The first module worked straight out of the box but the second one didn't. We resorted to the manual where it pointed out twice the importance of ensuring that the module completes a clean shut down sequence whilst still powered otherwise there is a risk of Flash contents corruption. The question was now whether this had been overlooked in our module. Using a scope it was possible to see a brief serial data stream on the GPS_TX output from the GPS module when it powered up.

To view the data we hooked up a USB/serial adapter cable to a PC (Figure 3) and ran Tera Term, a terminal emulator program. After a module reset we read the NEMA data string "\$PSRF150,1*3E" and then nothing. Looking in the support area of Maestro web site we checked the knowledge base to find a short article acknowledging the problem. Apparently it has been known to occur in a few 'rare cases'. Our (admittedly small) sample yields a probability of this fault occurring as 1 in 2! Not exactly rare.

The web site also has the SiRFFlash tool which needs installing, and the update 'GSD4e_4.1.2-P5Maestro.s' for our module. You can connect the module directly to the PC or use the expansion board update feature (fit jumper to JP3 and connect an FTDI cable to the odd-numbered pins of K3; remove jumper JP2, see **Figure 2**).

With the tool installed, follow the instructions outlined in the .pdf installation guide at the site. In our case the fix was successful.

Bug: <http://support.maestro-wireless.com/knowledgebase.php?article=6>

Reprogramming: <http://support.maestro-wireless.com/knowledgebase.php?article=13>

format. Altogether it uses just three connections to the FPGA board to send its data. With the signal GPS_ON/OFF (FPGA pin 84) the FPGA can switch the GPS receiver on or off. It is important to power down the GPS module in the correct sequence; it should be turned off using GPS_ON/OFF while it still has power. Failure to do so may result in corrupted flash memory contents. Pin RX0 of the GPS module receives serial data from the FPGA (pin 86). Control data is sent to the GPS module over this path. The module is already configured so does not need any additional configuration commands. At switch on the module communication parameters default to 4800 Bd, 8 data bits, no parity and one stop bit. Serial output TX0 from the GPS module connects to pin 85 of the FPGA. This output interface can be configured as either a UART or SPI. A 10 kΩ resistor between GPIO6 (pin 7 of the GPS module) and Vout (Pin 5) selects UART mode.

Pin 15 (TM_GPIO5) of the module outputs a signal of one pulse per second (1 p/s) when it is receiving signals from a sufficient number of satellites to enable a positional fix. There is insufficient drive current from this pin to directly light an LED so a transistor driver stage (T1) is incorporated. Connector K3 can be used to connect another GPS module or if you need a real serial port connection. K3 is compatible with the standard FTDI cable connector layout. The odd pins 7 and 9 are looped around to the even pins 10 and 8. Plugging in to the strip of odd-numbered pins gives you a 'straight through' connection. Plugging in to the even numbered strip swaps the RX and TX signals. This is useful for testing the GPS module using a PC or if you need to update its firmware. For the last case don't forget to fit jumper JP3. Jumper JP2 gives the option to power an external GPS module connected at K3 from 5 V or 3.3 V. Don't use K3 to supply power for the board. Remove the jumper on JP2 before connecting an FTDI here.

Power to the Boards

The expansion board needs both a 5 V and 3.3 V supply. The FPGA board, A/D converter and analog sensors are all powered from 5 V while the display, pushbuttons, LEDs and GPS receiver need 3.3 V. Each of the two rails requires around 100 mA. Power for the boards can be supplied by a mains power adapter with an output between 7 and

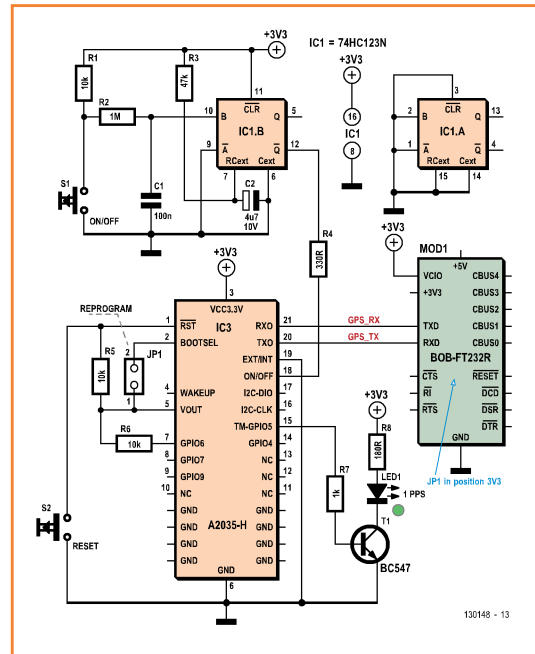

Figure 3. Hook up the PC and GPS module to update firmware.

12 V. The adapter cable plugs into socket K1, note that the centre pin of this connector is 0 V and the outer shell positive. The Schottky diode D1 protects the circuit from accidental supply voltage reversal.

Linear regulators are less efficient than switch-mode regulators, if we used a linear regulator here in place of IC1 to produce 5 V from a 12 V input it would dissipate around 1.6 W (ignoring current drawn by any additional circuitry connected to the expansion pins). Without a heatsink this would lead to unacceptable temperature rise of the limited PCB area and surrounding components and ultimately impact system reliability.

For this reason a step-down switching regulator was chosen. The IC LM2672N-5.0 (IC1) chosen for this job accepts a wide input voltage range from +6.5 V to +40 V and delivers 5 V with a current capability up to 1 A. The low-drop regulator IC2 derives the 3.3 V supply from the 5 V supply rail. In this case the voltage dropped across the regulator is just 1.6 V. The resulting power loss is just 160 mW which can be comfortably dissipated by the component surfaces with no need to resort to a more efficient switched regulator. Fit a jumper between pins 1 and 2 of JP1 to connect this regulator's 3.3 V output to the board components. Resistors R6 and R7 provide a convenient method to measure the current drawn from each of the voltage rails.

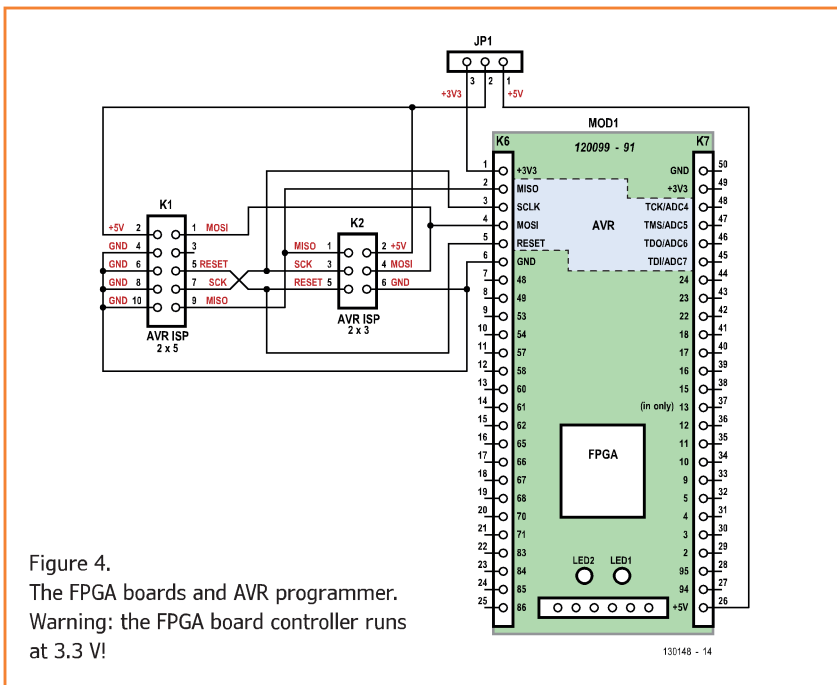

Figure 4. The FPGA boards and AVR programmer. Warning: the FPGA board controller runs at 3.3 V!

Don't forget to remove jumper JP1 from the plug-in FPGA development board when the whole system is powered from an external mains adapter. Be aware that there is a jumper labeled JP1 on both the development board and the expansion board.

For applications which only require low current it is possible to power the system completely from the USB connection on the FPGA development board. In this case switch the jumper from pins 1 and 2 of JP1 on the expansion board to pins 2 and 3. On the FPGA development board it is also necessary to fit a jumper to position JP1. Diode D3 in the expansion board circuit will now effectively isolate the 5 V regulator output.

When power is supplied from a mains adapter via K1 diode D3 introduces a 0.3 V voltage drop in the 5 V supply which is acceptable for most applications. In cases where a precise 5 V supply is required the regulator IC1 can be swapped for

The FPGA board gets new Firmware

Elektor reader 'ruudje' has made available a newer version of the FPGA board firmware at the [Elektor.Labs](http://www.elektor-labs.com) website. This version provides a much quicker boot sequence. Also other names for .exe files are now possible and a serial port is implemented.

To program the FPGA board it is necessary to hook up a 6-pin ISP connector to the SD card position (use the first 6 pins). You may need to make an adapter to connect an AVR programmer (see **Figure 4**). It's important to keep in mind that the ATmega32U4 is a 3.3 V variant and requires a compatible programmer. We used AVRDUDE together with an AVR-ISP-MK2 programmer from Olimex (we also needed to make up a 10/6 pin adapter). The command line for AVRDUDE is:

```
avrdude -c avrispmkII -P usb -p m32u4 -u -U
flash:w:FPGA_board_Config.hex
```

Once the new firmware has been flashed you can try out the features. Connect the FPGA board to a PC. When it was successful before, it should now also be possible to install the mass-storage driver. Otherwise consult the original article.

Also when the board is classified as a mass storage device Windows will indicate that it has found an unknown device.

Using the Windows Device Manager, install the driver contained in the INF file of the downloads for this article. The driver resides in the 'FPGA_board_Config_v1_0' folder, the device manager will then extract the information it needs. After a while you should see a message indicating that a communications port has been installed. The Device Manager will tell you which port number has been assigned. Y

ou can now talk to the board using a terminal emulator program like Tera Term. Make sure you configure the terminal emulator to use the port assigned to the board. Use the `STATUS` command to check that it is functioning correctly. The reply should look like this:

```
Startup configuration file = config.bin
FPGA configuration result = Successfully configured
Sd card type = SD version 2, 1875MB
```

That's all folks!

The exchange with ruudje can be found here:
www.elektor-labs.com/9130903536

Files: www.elektor-magazine.com/pub/Elektor%20Labs/120099_fpga

a type LM2672N-ADJ and the values of R4 and R5 adjusted to provide 5 V on the board. In this case you can use 1 % resistors, 5.1 kΩ for R4 and 1.5 kΩ for R5, the regulator now supplies 5.3 V which becomes +5 V after the voltage dropped by D3.

LEDs 1 to 3 indicate the supply status; LED1 = external supply available, LED2 = +5 V and LED3 = +3.3 V.

Assembly and testing

The design does not use any components that are difficult to fit so populating the boards will be quite straightforward. Start by fitting the smaller components and then go on to the larger items. Leave the fitting of IC2 to IC6, the FPGA development board and the display until the 5 V regulator circuitry has been fitted and tested. Once this has been tested fit IC2 and check that 3.3 V is at the output before fitting the remaining components. Pin 1 of the pressure sensor IC6 is identified by

a small nick along the edge of this lead; line this up with the white dot printed on the PCB.

It is a sensible precaution to initially solder the GPS module IC3 to the board using small lengths of thin hook-up wire. This gives you the opportunity to test the unit before finally soldering it into place. Once it is in its final position it will be tricky to de-solder it. There are two rows of four holes in the PCB under the GPS unit. They facilitate soldering the GPS earth plane to the expansion board ground (this is however not strictly necessary). A small hot-air station will be useful here if you choose to make the connection.

The color sensor packaging does not identify pin 1 instead it has a green dot at pin 4, the common cathode which is diagonally opposite pin 1. The sensor red segment should be aligned nearest the FPGA and the blue segment nearest the NTC thermistor (R8). Once all the components have

Advertisement

PCB-POOL
THE ORIGINAL SINCE 1994
Beta LAYOUT

create : electronics

FREE! SMT laser stencil
with every PCB Prototype order

Assembly service
From as little as one component

Embedded RFID
authenticate, track & protect
your product
www.magic-pcb.com

NEW!

Free Phone UK: 0800 389 8560
sales@pcb-pool.com

www.pcb-pool.com

Beta LAYOUT create: electronics

PCB-POOL® is a registered trademark of Beta LAYOUT GmbH. Registered brands remain the registered trademarks of the respective manufacturer!

eSTORE
Beta LAYOUT

Develop, assemble, solder

€ 38,95

Raspberry Pi Model B
512 MB RAM

Reflow Controller
€ 129,00

UHF RFID Starterkit Basic
€ 279,00

Large Beta-Reflow-Kit
€ 129,00

www.beta-eSTORE.com

Beta LAYOUT create: electronics

eSTORE® is a registered trademark of Beta LAYOUT GmbH

been fitted use a continuity tester to check the connections. A diode drop should be measured between the 5 V rail (cathode) and every output (anode).

There is a compiled executable available for the FPGA development board to help test the expansion board. Copy the file to an SD card and plug it into the development board slot. A few seconds after switch on the message 'Welcome' should appear on the first line of the display. An arrowhead displayed above S5 indicates that this should be pressed to progress with the test. Next is a small menu controlled program to test the function of switches S2 to S4.

When the GPS module is used under poor signal conditions it may take several hours before

it manages to get a positional fix. Activate the GPS module from the menu, LEDs 7 and 8 should flash; if not then GPS isn't running or has malfunctioned. When LED4 flashes at one second intervals it indicates that the module is functioning.

To read sensor values via the ADC menu use pushbutton S4 (REF). The A/D converter does not continually read the value; each press starts a new measurement. The temperature sensor should return a value of around 0x7C at average room temperature. The air pressure sensor supplies values up to 0xD0 in normal weather conditions. The color sensor requires a well-lit subject otherwise it returns low values.

75% of true size

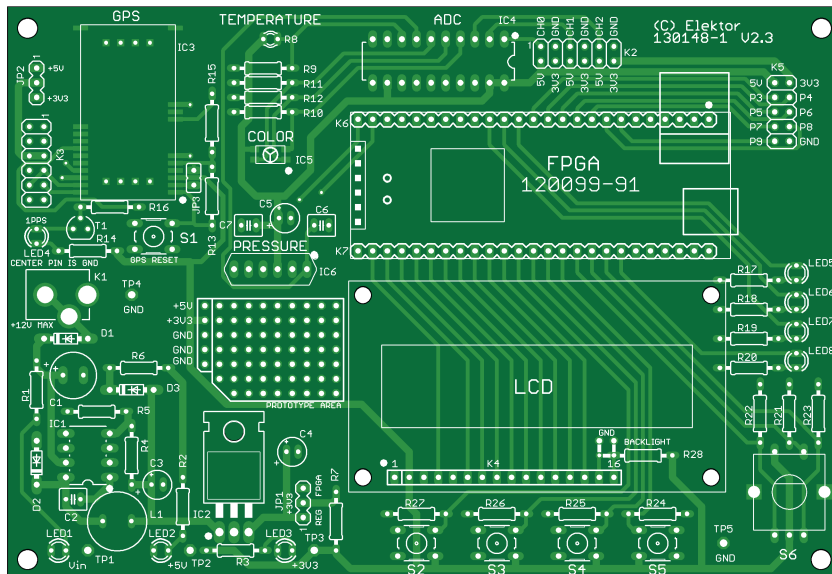

To be continued...

We've now looked at how to control the components and modules fitted on the expansion board. We mentioned that using VHDL is not so complicated.

In the next installment we will explain, with examples of simple control using VHDL.

(130148)

Internet Link

[1] www.elektor-magazine.com/130148

COMPONENT LIST

Resistors

(.25W except R6,R7)
 R1,R16 = 1kΩ
 R2 = 390Ω
 R3,R14,R17-R20 = 180Ω
 R4 = 0Ω*
 R5,R28 = not fitted *
 R6,R7 = 1Ω 0.5 W
 R8 = NTC 22kΩ, type ND03P00223J
 R9 = 22kΩ
 R10 = 820kΩ
 R11 = 510kΩ
 R12 = 390kΩ
 R13,R15,R21-R27 = 10kΩ

Capacitors

C1 = 330μF 16 V
 C2,C7 = 10nF ceramic
 C3 = 68μF 16V

C4 = 10μ 10V
 C5 = 1μF 16V electrolytic
 C6 = 470pF 50V ceramic

Inductors

L1 = 33μH 1.4 A

Semiconductors

LED1-LED8 = LED, green, 3mm
 D1,D2,D3 = 1N5817 (Schottky)
 T1 = BC547
 IC1 = LM2672N-5.0, switch-mode regulator
 IC2 = MCP1825S-33EAB, low-drop regulator
 IC3 = A2035-H, GPS Module (Newark / Farnell # 2281693)
 IC4 = ADC0838CCN/NOPB, ADC
 IC5 = KPS-5130PD7C, color sensor
 IC6 = MPX4115A, pressure sensor

Miscellaneous

JP1,JP2 = 3-pin pinheader, 0.1" pitch
 JP3 = 2-pin pinheader, 0.1" pitch
 K1 = adapter socket with center pin
 K2,K3 = 12-pin (2x6) pinheader, 0.1" pitch
 K4 = 16-pin pinheader, 0.1" pitch
 K5 = 10-pin (2x5) pinheader, 0.1" pitch
 K6,K7 = 25-way SIL receptacle for FPGA Board
 LCD = 2x16 characters, HD44780-compatible (Newark /Farnell # 1847939)
 S1-S5 = pushbutton, 6x6 mm
 S6 = EC12E rotary encoder, 24 P/U, with pushbutton
 8-pin IC socket for IC1 (optional)
 20-pin IC socket for IC4 (optional)
 16-way SIL receptacle for LCD, 0.1" pitch
 PCB #130148-1 rev2.3

Take out a FREE membership to Elektor.POST

- The latest on electronics and information technology
- Videos, hints, tips, offers and more
- Exclusive bi-weekly project for GREEN and GOLD members
- Elektor behind the scenes
- In your email inbox each Friday



Register today at www.elektor.com/newsletter

THINKING AUDIO OVER IP APPLICATIONS ARE HARD?



EVEN KIDS CAN DO IT WITH SOOLUTIONS



ISL0A11E/SE
One-way voice-band IP-PA System (PA over IP)

ISL0A12E/SE
One-way broad-band IP-PA System (PA over IP)

ISL0A15E/SE
Two-way peer-to-peer (P2P) voice-band and broad-band (Intercom)

All solutions available in clear and secure modes

www.solutions.com



Mastering Microcontrollers Helped by Arduino

NEW

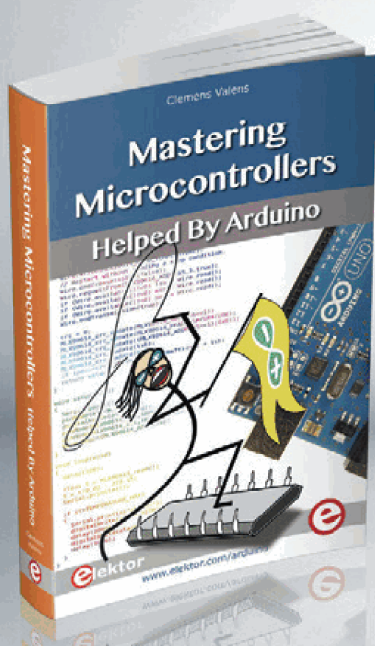

This book will not only familiarize you with the world of Arduino. The author, Elektor Expert Clemens Valens, also provides the reader with the basic theoretical knowledge necessary to program any microcontroller: inputs and outputs (analog and digital), interrupts, communication buses (RS-232, SPI, I²C, 1-wire, SMBus, etc.), timers, and much more. The programs and sketches presented in the book show how to use a variety of common electronic components: matrix keyboards, displays (LED, alphanumeric and graphic color LCD), motors, sensors (temperature, pressure, humidity, sound, light, and infrared), rotary encoders, piezo buzzers, pushbuttons, relays, etc. Theory is put into practice on an Arduino board using the Arduino programming environment. This book will be your first book about microcontrollers with a happy ending!

348 pages • ISBN 978-1-907920-23-3
£34.95 • € 39.95 • US \$56.40

10% OFF for GREEN and GOLD Members

Further Information and Ordering at www.elektor.com/arduinobook

Home and Office Network Tester

Effortless Ethernet connections

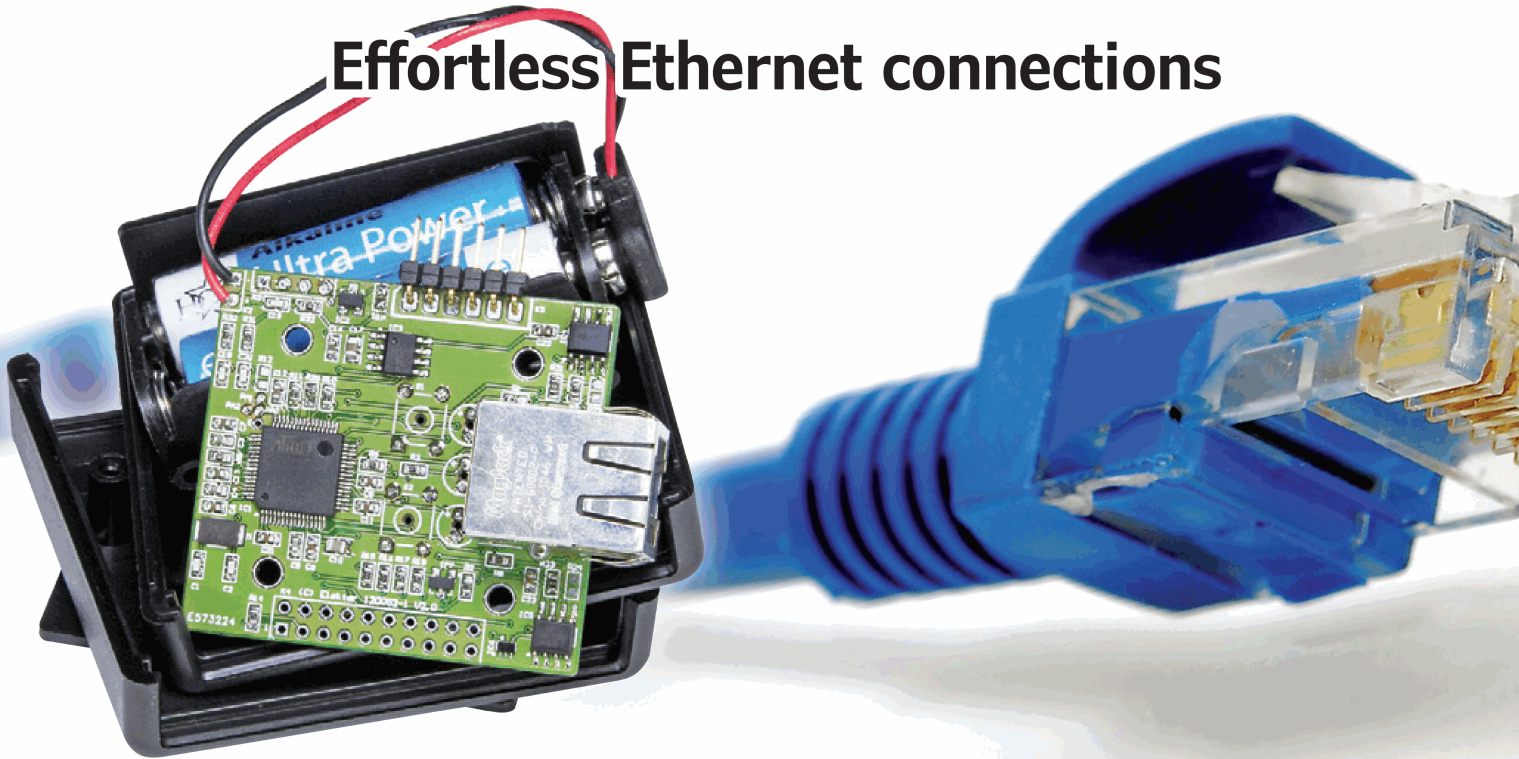

Testing TCP/IP networks can be a hassle. This small, battery powered circuit makes your life a whole lot easier by auto-testing any hard wired network for various levels of operation.

By
Jeremy Bentham
(UK)

Because I supposedly “know about networking”, I’m frequently asked to do fault-finding, and go through the same steps each time; check network cabling, router communications, DHCP negotiation, ADSL communication, Internet connectivity, et cetera. These steps are difficult to describe to network novices, due to the vagaries of operating systems and network configurations, so this unit was designed to automate the process, providing a simple display that anyone can understand. The circuit presented here offers easy one-button testing of common home and office networks, with red-amber-green indication of the network status, and any faults. The design is really simple, just a microcontroller, an Ethernet interface, a pushbutton for starting the test and status LEDs to show the condition of the network. You can’t expect a simple low-cost unit such as this to test everything. Nevertheless, this design does do a

lot more than a simple cable tester:

- Low-level: is the cable connected?
- Medium-level: is there connectivity to an Internet gateway?
- High-level: is there connectivity to the Internet?

Where is the Ethernet controller?

The design offers a ground-breaking feature: an Ethernet interface without an Ethernet controller. This has various advantages:

- Simpler hardware design
- Much lower power consumption
- Simpler device drivers
- Educational: not an obscured ‘black-box’ design.

Omitting the Ethernet controller has its difficulties. Microcontrollers often lack the necessary

hardware to implement a serial protocol, and it isn't unusual for the software to direct-drive I/O lines to create the same effect: a process commonly known as 'bit-bashing' or 'bit-banging'. Software drivers for RS232, I²C, SPI and even low-speed USB are readily available, but the much higher data rate of Ethernet (10 Mbit/s) presents a major challenge.

The data is Manchester-encoded. The software has to prepare 'raw' frame data, with a minimum of two samples per bit, making the minimum transmit data rate 20 Mbit/s. Receiving requires an even higher rate; in the absence of any hardware to lock in to the incoming signal, it is necessary to read in the data much faster, then do edge-detection in software. So we need a microcontroller with shift registers that can handle at least four times the bit-rate; in this design, they are clocked at 48 Mbit/s, with a fractional-division algorithm to produce the correct data rate.

There is no point reading in the data if it can't be stored in memory, and even a simple CPU read-store-increment loop can be too slow for the incoming 6 Mbytes/sec. Fortunately there is one microcontroller family that can manage this; the ARM-based SAM7 series. The standard ARM architecture isn't up to the task, but Atmel have turbo-charged the chip by adding fast data-handling hardware, most notably DMA (Direct Memory Access) controllers to transfer data to and from the shift registers without CPU intervention. Even with this acceleration, the microcontroller is working very hard for the duration of the Ethernet transfers; its internal data busses are saturated, so the CPU can only idle at this time. However, this situation is not unusual with network interfaces; there is a brief period of frenetic activity when transmitting, a (relatively) long wait for the response, then another period of intense activity decoding the incoming message.

As ever, there is a trade-off between hardware and software complexity, and this project pushes that boundary to the limit; it is amazing that a small microcontroller consuming around 100 mW can achieve this level of performance.

Hardware

The block diagram (**Figure 1**) shows the principle elements of the design, demonstrating its inherent simplicity. The Serial Peripheral Inter-

Features

- Low-level Ethernet interface
- Internet Protocol (IP) and User Datagram Protocol (UDP) encapsulation
- Dynamic Host Configuration Protocol (DHCP), client
- Internet Control Message Protocol (ICMP) Echo Request (Ping) client & server
- Address Resolution Protocol (ARP) client and server
- Domain Name System (DNS) client

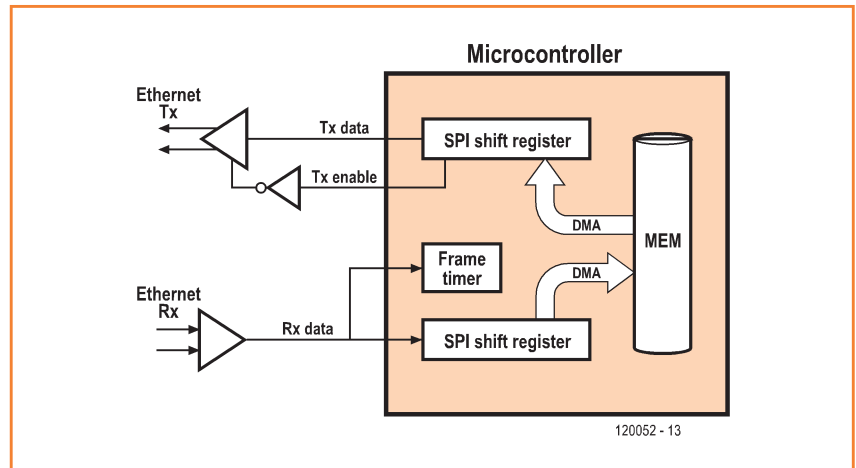

face (SPI) shift registers in the microcontroller handle the network traffic, with DMA controllers to transfer data to and from memory. Transceiver ICs act as buffers between the network and the processor, the transmit buffer being controlled by the chip-select output of the SPI interface. The frame timer solves the tricky problem of detecting when the end-of-frame has been reached; the processor can't do this without disrupting the incoming data flow, so a microcontroller timer is configured as a retriggerable monostable, generating an interrupt when the received data line stops toggling.

Turning to the circuit diagram, despite looking rather intimidating, it really isn't all that complicated (see **Figure 2**). It's just that the microcontroller (IC1) has a lot of pins and takes up a lot of space (in the schematic, not on the PCB). There are several pin-compatible parts in the Atmel SAM7 range that can be fitted to the board, differing mainly in the memory sizes. AT91SAM7S128, 256 and 512 have been tested, smaller parts such as the AT91SAM7S32 or 64 will not work due to the demands of Ethernet transmission.

The design does include some optional features;

Figure 1. The block diagram demonstrates the inherent simplicity of the circuit.

programming the CPU is via JTAG (K4) or USB (K3); if the latter is used, K4 may be omitted. IC3 is an optional 256Kbit EEPROM for storing configuration data, not used in the current software. K1 is an Ethernet connector with built-in transformer; R21-24 use a combination of zero-ohm links and not placed (NP) parts to provide some capability for accommodating alternative pinouts, but there is very little standardization amongst these devices, so careful study of the datasheet

is necessary if contemplating alternatives. IC4 and 5 are transceivers that buffer the network interface, turning the single-ended microcontroller SPI signals into differential lines for the network. The transmitter IC5 is enabled using the SPI Chip Select output, with inverter IC6 to correct the polarity. And finally IC7 is a voltage supervisory device that keeps the microcontroller in reset until the system voltage has reached the proper level and stabilizes.

Ethernet

We are using is 10BaseT Ethernet, where the 10 refers to the bit rate in Mbit/s, and the 'T' means a twisted-pair interface. Although slow by modern standards, this rate is more than adequate for testing networks. Even the fastest of Ethernet hubs will auto-configure to a lower rate when necessary.

The hardware uses two twisted pairs, transmit and receive, on an RJ45 connector. These are normally transformer-coupled, to avoid any ground-loop problems. When an Ethernet node is connected to a hub, it announces itself sending Link Integrity Test (LIT) pulses on the transmit line; a simple 100-200 ns pulse every 16 ms is all that is needed to light the 'link' LED on the hub, and enable its network interface. Patterns of these pulses can also be sent, to allow communication between the unit and the hub, a process called auto-negotiation, but the current software plays dumb, and sends simple pulses.

An Ethernet message (frame) contains bit-wise data, plus extra information needed to synchronize the receiver and transmitter. There are two elements to this synchronization: bit-sync and byte-sync. Each bit is synchronized by ensuring there is at least 1 edge per bit-time, the 0 and 1 values being marked by either 1 or 2 edges within the bit-time; this is known as Manchester encoding. This coding method can take various forms, Ethernet uses a non-return-to-zero (NRZ) method, whereby a single edge per bit-time indicates a data transition (0-to-1, or 1-to-0) and two edges indicate a constant data value (all 0 or all 1).

Byte synchronization is achieved by sending a preamble (a known training sequence) and a start-of-frame-delimiter (single byte to mark the start of data). At the end of the frame there is a 4-byte Cyclic Redundancy Check (CRC) so the message integrity can be checked.

Each frame carries a payload of 60 to 1514 bytes; if less than 60 is needed, it must be padded to the minimum length, in order to maintain the hardware timing specifications. The payload has 6-byte source & destination

addresses, a two-byte field indicating the type of data that follows, and up to 1500 bytes of frame data. This will house an Internet Protocol (IP) frame, the lowest level of the TCP/IP stack.

A final piece of Internet magic is how the network 'knows' where to send the data, either to a local system, or one that is far-distant. The trick is that for any given address, a node only needs to determine if the destination is local or remote. If local, it is sent direct across the current network ('subnet' in IP parlance) to the recipient, if remote, it is sent to a

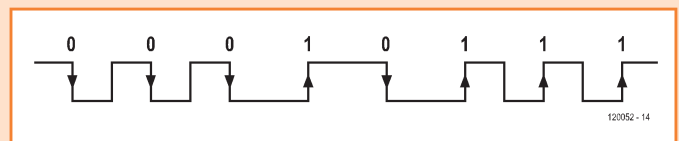

NRZ Manchester coding.

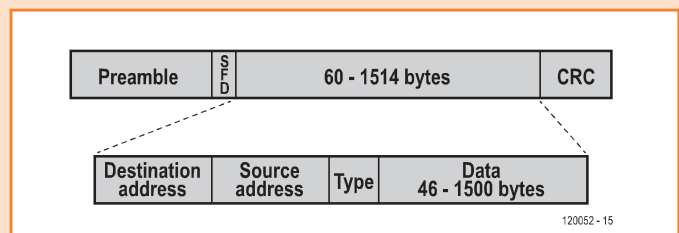

Ethernet frame byte format.

router, which knows how to forward it on to the destination. This explains a critical frustration with TCP/IP networking: You can have two adjacent systems on your bench refusing to communicate, as the network configuration is telling them they are remote from each other. So your local network traffic ends up on the Internet, seeking a far-distant home, when the real destination is a few meters away. Such is the power, and frustration, of Internet communications!

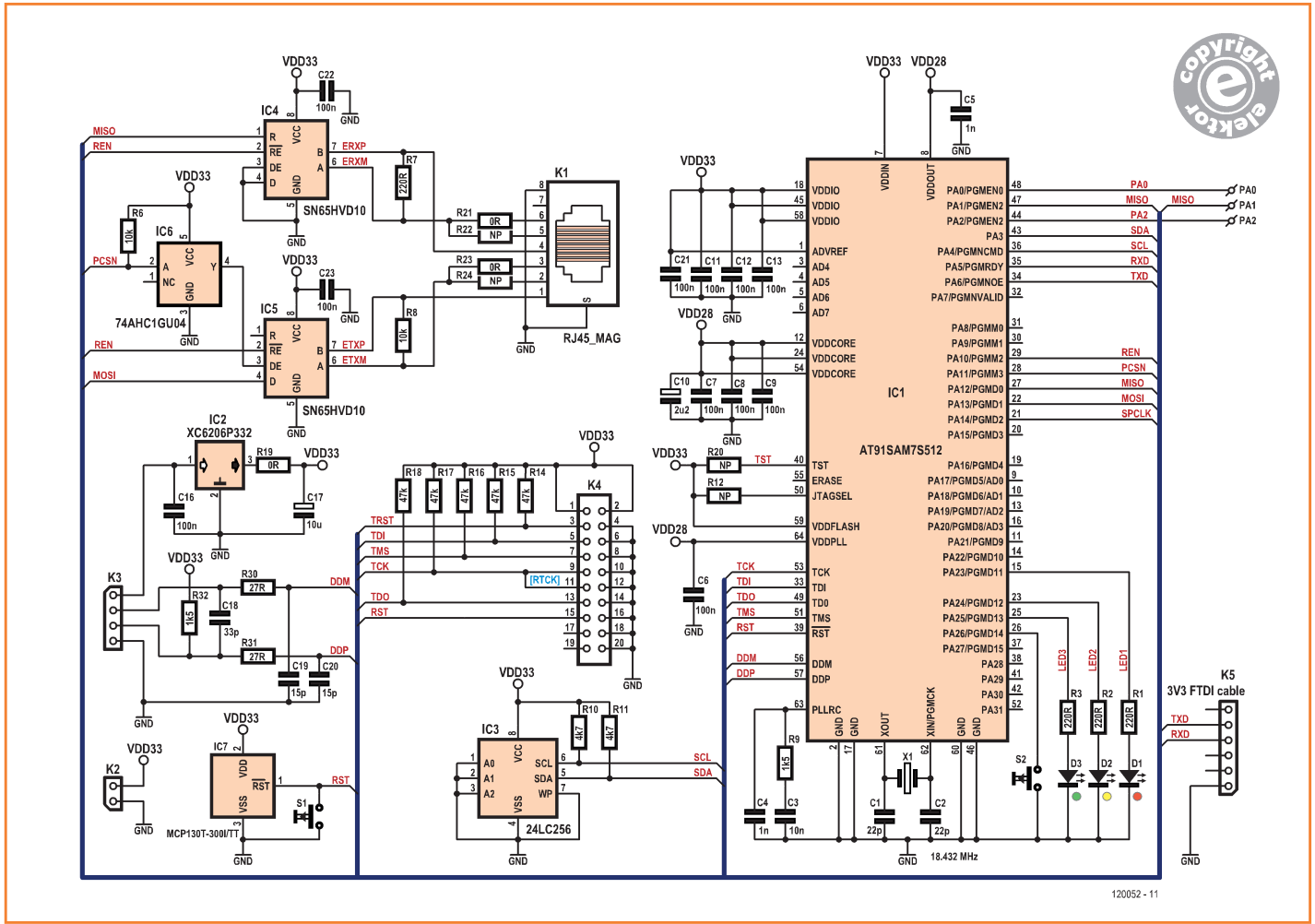

120052 - 11

All of the capacitors are for decoupling or buffering of the supply voltage, except for C1 and C2, which stabilize the clock for IC1, and C18-20, which form a low pass filter so the data signals conform to the USB specification. Parts R9/C3/C4 are required to stabilize the microcontroller's internal phase-lock-loop, which scales the xtal frequency up to the desired CPU clock.

S1 resets the microcontroller and S2 starts a test sequence. K3 can be used to connect the microcontroller to a PC. The correct pinout is shown in **Figure 3**. The unbuffered serial lines on K5 provide a simple way of getting diagnostic information from the CPU; useful diagnostic messages are emitted at 38,400 baud, which can be viewed by connecting a 3.3 V FTDI serial-to-USB cable. There are three different ways to power the circuit:

1. via USB. Make sure that R19 (0 ohms) is mounted and that there's no (battery) supply connected to K2.
2. via the FTDI cable. Check that R19 is mounted and that there's no USB cable connected. Run a jumper wire from K5 pin 3 to K3 pin 1; no supply connected to K1. Please note that the 3.3 V FTDI-cables have 5 V supply on their VDD connection—do not hook that directly up to the 3.3 V supply of the tester!

Figure 2. The circuit isn't all that complicated. Just the microcontroller has a lot of pins that are connected.

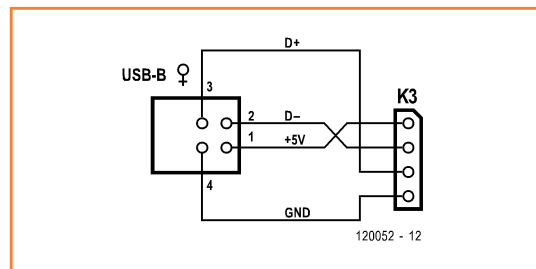

120052 - 12

Figure 3. A USB connection to the microcontroller can be established using this diagram.

COMPONENT LIST

Resistors

(all 0603)

- R1,R2,R3,R7 = 220Ω 1%
- R6,R8 = 10kΩ 1%
- R9,R32 = 1.5kΩ 1%
- R10,R11 = 4.7kΩ 1%
- R12,R19,R20,R21,R22,R23,
R24 = 0Ω, not mounted, see
text
- R14,R15,R16,R17,
R18 = 47kΩ 1%
- R30,R31 = 27Ω 1%

Capacitors

(0603 unless specified otherwise)

- C1,C2 = 22pF 5%
- C3 = 10nF 10%
- C4,C5 = 1nF 10%
- C6,C7,C8,C9,C11,C12,C13,C16,
C21,C22,C23 = 100nF 20%
- C10 = 2.2μF 6.3V 10%, 0805
- C17 = 10 μF 6.3V 20%, 0805
- C18 = 33pF 5%
- C19,C20 = 15pF 5%

Semiconductors

- D1 = LED 3mm, red, low current
- D2 = LED 3mm, yellow, low
current
- D3 = LED 3mm, green, low
current
- IC1 = AT91SAM7S512
- IC2 = XC6206P332
- IC3 = 24LC256
- IC4,IC5 = 65HVD10
- IC6 = 74AHC1GU04
- IC7 = MCP130

Miscellaneous

- K1 = RJ45 jack with integrated mag-
netics (Stewart Connector type
SI-60002-F)
- K2 = 2-pin pinheader, 0.1" pitch
- K3 = 4-pin pinheader, 0.1" pitch
- K4 = 20-pin (2x10) pinheader, 0.1"

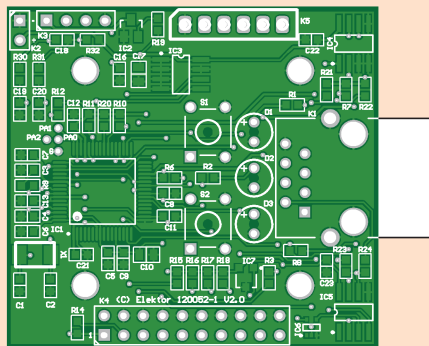
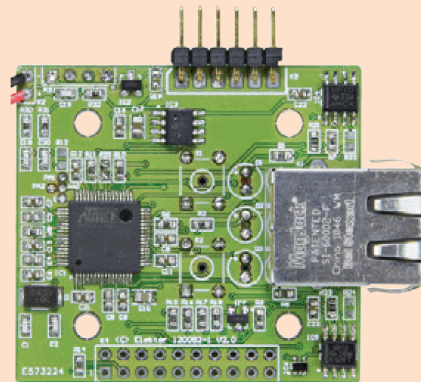

Figure 4. The 64-pin LQFP package with its lead pitch of 0.5 mm will be a challenge to mount.



- pitch
- K5 = 6-pin pinheader, 0.1" pitch
- S1,S2 = tactile switch, 6mm square
- X1 = 18.432MHz quartz crystal,
5x3.2mm
- Case Hammond 1593PGY
- FTDI cable 3V3
- PCB # 120052

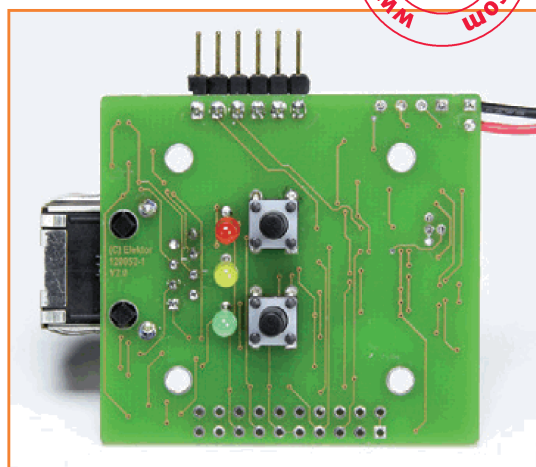

Figure 5. With the switches and LEDs mounted on the bottom, the circuit is easily built into a small enclosure.

3. Battery powered. Two 1.5 V AA cells can power the tester for portable analysis. In this case R19 is not mounted, so it doesn't matter if power is connected to the USB and/or FTDI connector. This is useful for portability. As the overall supply current is around 50 mA, two AA cells should provide many hours of operation. As soon as the battery voltage drops below 3.0 V, IC7 will reset the ARM controller.

The components that are used in this circuit are readily available from catalogue suppliers at modest cost. Surface-mount assembly (SMA) will be required. Soldering the microcontroller—housed in a 64-pin LQFP package with a lead pitch of 0.5 mm—will be beyond the capability of many enthusiast builders and may even pose a challenge to the more experienced engineer; the Elektor book *LabWorX 2: Mastering Surface Mount Technology* [1] is recommended reading, together with a supply of fine solder wick, to remove the inevitable solder bridges between pins. The PCB (Figure 4) has been designed to fit within a Hammond case, with the switches and LEDs mounted on the underside of the board (see Figure 5), poking through drilled holes. Alternatively, all the components may be mounted on the top side of the board, which is more convenient when using an uncased board for bench-testing.

Programming and testing

There are two ways of programming the unit; the conventional way for ARM processors is the JTAG interface K4, and a suitable USB-JTAG adaptor, such as the J-Link ARM. When used with an appropriate development environment, this method provides an excellent source-level debug capability—but at a cost.

A low-cost alternative is the special software tool provided by Atmel called SAM-BA (SAM Boot Assistant) for programming firmware via the USB port of the network analyzer. This utility is free for download on Atmel's website; there are versions for Windows and Linux. We've only used V2.12 for Windows. The microcontroller has a boot loader mechanism that must be activated by pulling the PA0, PA1, PA2 and TST pins high while powering up and waiting for about ten seconds. Then power off, release these four pins and power up again. After that, SAM-BA can be started on your PC and the firmware transferred to the flash memory of the microcontroller.

On the PCB all these four pins of the microcontroller are accessible. TST can directly be connected to VDD via a zero Ohm resistor R20, the three port pins have an extra connection by the side of the AT91SAM7S that can be connected to VDD using jumper wires. The whole module can be USB powered by shorting R19, so no external power supply is needed while programming the network tester.

Connect a USB cable between K3 and a free port on your computer. Windows will report that the USB device is not recognized, don't worry about that for now. Wait for about ten seconds (a few more won't harm) and then unplug the USB cable. Remove the connections of the three port pins and TST pin. R19 will remain shorted until later. Now connect the USB cable again, Windows should recognize the device now as an 'AT91 USB to serial converter' and install the corresponding driver. When you start SAM-BA, select the correct type of microcontroller in the board field, in this case 'at91sam7s256-ek', see

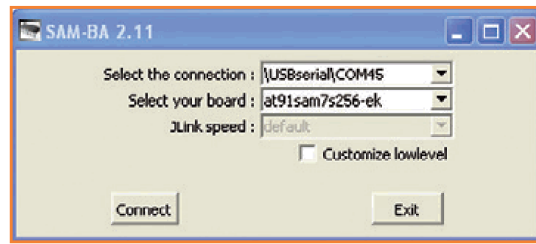

Figure 6. Programming with SAM-BA is very straightforward.

Figure 6. Click on 'connect' to start communication with the network tester. Then select the binary file for the microcontroller and click on 'program'. The firmware will then be loaded into the flash memory of the ARM processor. Now the processor must be reset, either by power cycling or pushing reset button S1. D1 should blink every two or three seconds, signaling the micro is running.

In an ideal world, the USB interface would also provide diagnostic information on the inner workings of the software, but the code is already quite complex, so that accommodating the USB drivers,

Diagnosics

The software transmits diagnostics on the K5 serial link at 38,400 baud. Here's an example:

```
ETHERLEAN v0.34
```

```
00:0B:75:01:02:03->FF:FF:FF:FF:FF:FF IP len 278 0.0.0.0->255.255.255.255 DHCP
00:24:FE:C8:9B:75->00:0B:75:01:02:03 IP len 576 10.1.1.100->10.1.1.221 DHCP
00:0B:75:01:02:03->FF:FF:FF:FF:FF:FF IP len 278 10.1.1.221->255.255.255.255 DHCP
00:24:FE:C8:9B:75->00:0B:75:01:02:03 IP len 576 10.1.1.100->10.1.1.221 DHCP
DHCP ACK: my IP 10.1.1.221 router 10.1.1.100 DNS 10.1.1.100
```

```
00:0B:75:01:02:03->FF:FF:FF:FF:FF:FF ARP REQ 10.1.1.221->10.1.1.100
00:24:FE:C8:9B:75->00:0B:75:01:02:03 ARP RSP 10.1.1.100->10.1.1.221
```

```
00:0B:75:01:02:03->00:24:FE:C8:9B:75 IP len 61 10.1.1.221->10.1.1.100 DNS
00:24:FE:C8:9B:75->00:0B:75:01:02:03 IP len 157 10.1.1.100->10.1.1.221 DNS
DNS: www.elektor.com 92.52.84.11
```

The DHCP transactions show the unit requesting the allocation of an IP address, and being given 10.1.1.221 by the server, which also provides addresses for contacting the Internet (via a router at 10.1.1.100) and resolving host names (via a DNS server at 10.1.1.100). The unit uses Address Resolution Protocol (ARP) to find a hardware address for 10.1.1.100, then puts through a DNS request, asking for the address of that well-known Web site, www.elektor.com. The DNS server gives the response 92.52.84.11, showing that all is well with the Ethernet, DHCP and DNS; the most common points of network failure.

It is educational to watch the protocol transfers using monitoring software running on a PC. A good monitoring program is the excellent free Wireshark, which can display network traffic in considerable detail. Be warned though, modern Ethernet hubs (switches) intelligently route network data across their ports, and see no reason to send all the traffic to a monitoring PC. There are two solutions to this problem; either an expensive 'managed' switch, which can be configured to copy traffic across to a specific port, or the opposite approach: an old Ethernet hub that has no intelligence, and copies all traffic to all ports.



and getting them to cooperate with the Ethernet code, is one challenge too many for the author. Instead, the software transmits messages on the K5 serial link at 38,400 baud; terse, but highly informative. An example is given in the inset 'Diagnostics'.

Software

The essence of networking software is a layered approach; when transmitting, the data passes down through the layers, each of which adds encapsulation with headers and/or trailers, until it is sent on the network. On arrival at its destination, the encapsulation is stripped off as the data travels back up through the layers, until it emerges at the top in the original form it was sent. This begs the question: why bother with all these layers, why not send the data as-is? Well, firstly, if you want to communicate over the Internet, you must play by its rules, and these mandate the TCP/IP family of protocols. Secondly, each layer provides specific functionality, for example:

- Ethernet is a low-level transport, with 6-byte hardware (MAC) addresses;
- IP provides 4-byte logical addresses, which are mapped onto MAC addresses;
- ARP provides a mechanism for translating MAC addresses to IP addresses;
- ICMP allows low-level diagnostic messages (pings) to be sent and received;
- DHCP allows a computer to establish a network identity, using only a MAC address;
- DNS provides a method of translating a domain name into an IP address.

Using TCP/IP protocols, two computers can communicate with each other at opposite sides of the earth, as easily as if they were connected to the same network hub; but this capability is only obtained at the price of considerable complexity. There are many books on TCP, including the author's 'TCP/IP Lean', sadly now out of print.

Less well documented is the process for generating and decoding Ethernet frames. We'll have a stab at it in the inset 'Ethernet'.

Despite the external simplicity of the unit, there is a significant amount of software for handling the low-level Ethernet interface, the higher-level TCP/IP functions and the user interface (button and LEDs). There is no operating system, real-time kernel or third-party TCP/IP stack; all the software is custom-written, or adapted from the author's 'TCP/IP Lean' code. The software, available for free from [2], is written in C, using the IAR EWARM development environment. The code is sufficiently small that the free 'kickstart' edition can be used; it will also be adapted for use with the GNU toolset when time permits. The software will be released under an open-source license.

(120052)

Internet Links

[1] www.elektor.com/labworx

[2] www.elektor-magazine.com/120052

About the Author

Jeremy Bentham is an embedded systems designer, producing hardware, software and PCB designs professionally. He wrote the book 'TCP/IP Lean; Web Servers for Embedded Systems', quite a popular book that was even translated into Chinese. Nowadays, hardware and software consultancy work has taken precedence over writing.

Professional Quality
Trusted Service
Secure Ordering



Elektor PCB Service at a glance:

- ➔ 4 Targeted pooling services and 1 non-pooling service
- ➔ Free online PCB data verification service
- ➔ Online price calculator available
- ➔ No minimum order value
- ➔ No film charges or start-up charges

Delivery
from 2
working
days

USB Battery Tester

Battery testing with a USB-IO24 cable

By **Joachim Schröder** (Germany) and
Tim Uiterwijk (Elektor Labs)

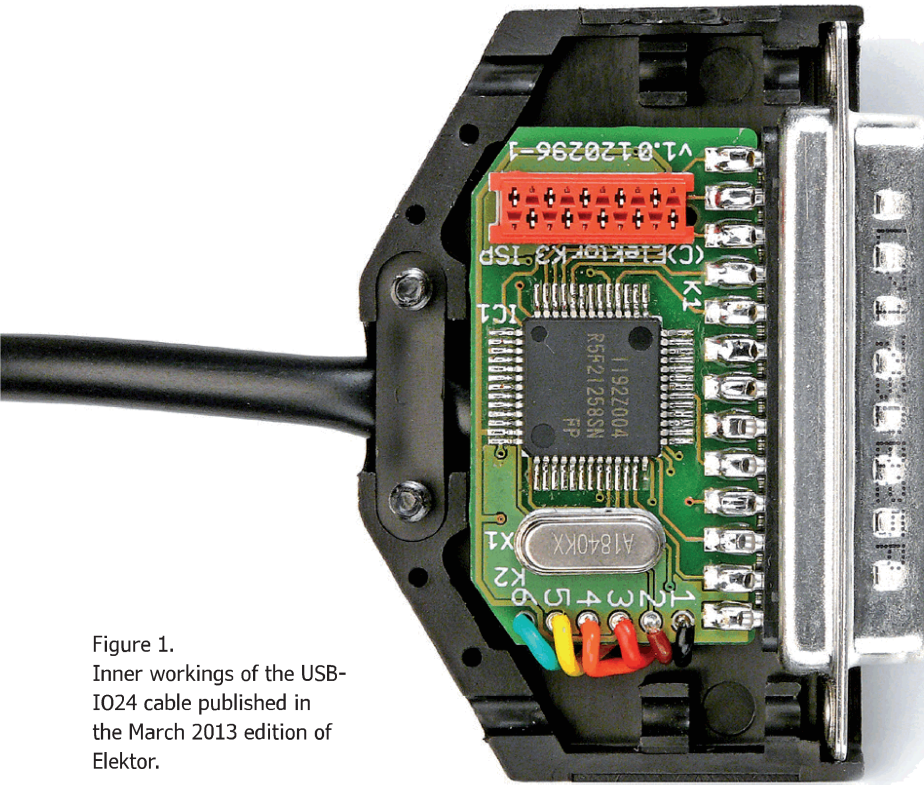

Figure 1.
Inner workings of the USB-IO24 cable published in the March 2013 edition of Elektor.

Testing batteries is a fairly common task among electronics enthusiasts. Instead of using a complex stand-alone meter, you can put the intelligence of a PC to good use for this. This is not difficult, thanks to the general-purpose PC connection provided by the USB-IO24 cable presented in a previous edition of Elektor magazine. The only thing you have to add is the battery interface described here.

When the USB-IO24 cable [1], a general-purpose and convenient adapter for measuring and controlling external devices from a PC, was first described in Elektor magazine in December 2012, Joachim Schröder resolved to put this handy device to good use. He set about designing a sort of battery interface for the cable that would allow him to test batteries in a very elegant manner. He presented the result of his efforts on the Elektor Projects website [2], where it met with general interest and received good ratings. The project was quickly checked out by Elektor, and now it is being published in the magazine with the support of Elektor Labs staff member Tim Uiterwijk.

The cable

In light of the capabilities of the USB-IO24 cable, the designation “cable” is a bit of an understatement for the project described in [1]. Neverthe-

less, it is suitable because nearly all of the circuitry fits in the shell of a 25-pin Sub-D connector—as you can see from **Figure 1**. The result is a general-purpose interface cable with many practical uses. At one end it has a USB connector that plugs into a PC, while at the other end it has a plug-and-socket connector that can be attached to any desired external hardware.

The nice thing about this arrangement is that you can use the cable to control a wide variety of external devices, or make measurements on external devices, that you do not need every day. This means you do not need to have a rat’s nest of cables connected to your PC, or a large number of virtual COM ports. That keeps things neat and tidy under your desk and in the operating system. What’s more, writing software for this cable is easy. To learn more about the cable’s features and what it can do, have a look at the “USB-IO24

Cable” inset. Part of the cable is entirely suitable for DIY construction. You can order a blank PCB, a fully programmed microcontroller or a fully assembled and tested board from the Elektor Store [1]. You can also purchase the basic USB cable for this purpose (with an integrated FT232R serial to USB converter) from the shop or from other sources.

The basic structure of the USB-IO24 cable is as follows: The ready-made FTDI cable, with a USB connector at one end and open leads at the other end, converts the USB data stream into a serial bit stream, and a suitably programmed microcontroller inside the shell of the D Sub connector attached to the end of the cable converts the serial data into the types of signals usually necessary for external hardware connected to the end of the cable: digital I/O signals, analog inputs, PWM outputs and so on. Only a few components are necessary at the “far end” to implement a wide variety of intelligent projects.

The battery interface

There are several key parameters that must be measured in order to test a battery. From a purely electrical perspective, you have to be able to measure the current (charge or discharge) and the battery voltage. It’s also worthwhile to be able to not only measure the discharge current, but also set and control the current. Since a good

Features

- Measures battery capacity and internal resistance
- Built-in battery refresh function
- Suitable for 12 V lead-acid batteries
- Maximum discharge current 8 A
- Simple circuit thanks to USB-IO24 cable

deal of heat is dissipated when a battery is discharged, it’s a good idea to use something better than simple passive cooling. A variable-speed fan is necessary for this. In total, you need to measure two analog signals (current and voltage) with the USB-IO24 cable and output two semi-analog signals (for current level and fan speed) from the cable.

The job of the circuitry connected to the cable is therefore to process the sensed values of the battery current and voltage so that the resulting voltages are compatible with the measuring range of the analog inputs of the USB-IO24 cable. It must also generate the PWM outputs in the form necessary to allow specific currents and fan speeds to be set.

The necessary signal processing, or in electronics jargon the interfacing of these signals, is handled by the circuit designed by Joachim Schröder, which is shown in **Figure 2**.

USB-IO24 Cable

The design originally published in the March 2013 issue of Elektor magazine consists primarily of a small double-sided PCB precisely dimensioned to fit inside the shell of a 25-pin Sub-D connector. The PCB is fitted with a Renesas R85/C microcontroller that receives and returns serial data in this application. This allows all analog and digital signals typically necessary for controlling and monitoring external hardware to be available on the pins of the D Sub connector. The other end of the cable is fitted with an FTDI USB/TTL IC, which is widely known and used in many applications. This IC converts USB signals into TTL-compatible serial data signals, and the driver that is automatically installed in modern Windows systems provides a virtual COM port that makes the programming of matching software really easy. The USB side of the cable is encapsulated, so constructing the complete cable is limited to fitting the small PCB in the D Sub shell and connecting the leads of the ready-made USB cable.

The USB-IO24 cable offers up to 24 digital I/O pins or up to eight analog inputs, PWM outputs and RC servo signals, each with 10-bit resolution, as well as four 16-bit counter inputs. The associated article [1], which can also be obtained as a PDF file, describes the construction, initial use and programming of the cable and additionally provides some application examples with demo code. It is worth reading if you want to know in detail what you can do with the cable.

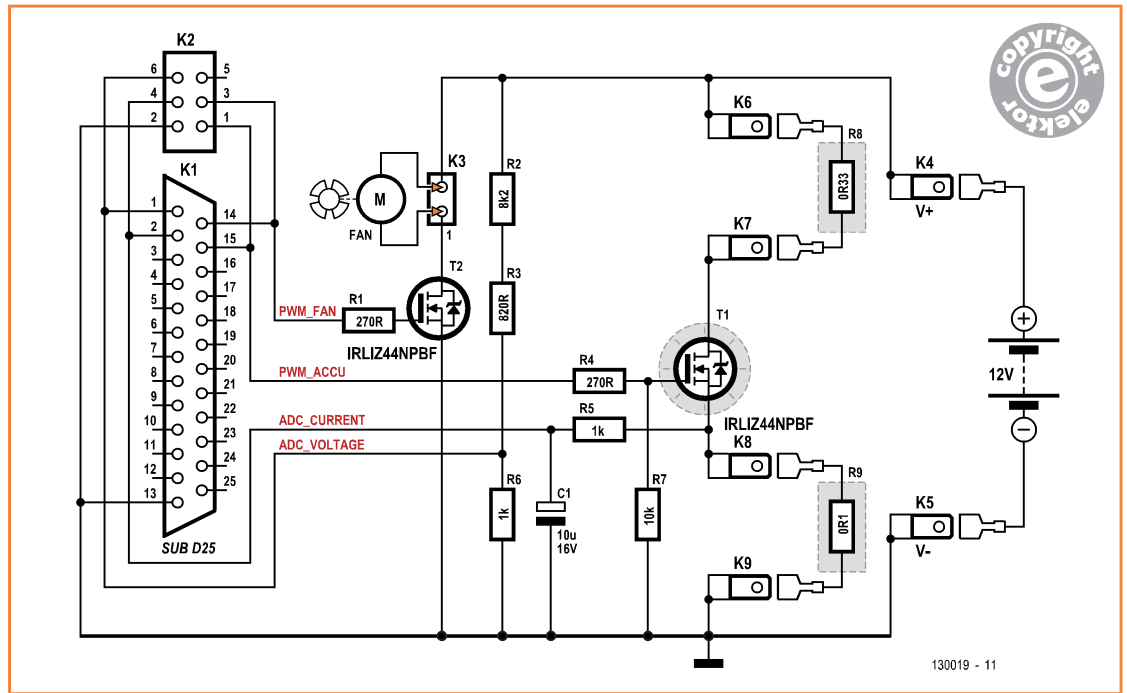

Figure 2. Aside from the USB-I024 cable, only a few components are necessary to implement a full-fledged PC-controlled battery tester.

The voltage of the battery connected to blade terminals K4 and K5 is first reduced by a voltage divider, consisting of R2, R3 and R6, to a level suitable for the analog input of the cable. The input measuring range of 0–5 V yields a maximum measurable terminal voltage of 50 V. The converter resolution is 10 bits, which makes the smallest measurable increment 50 mV. This measuring range is therefore quite suitable for 12 V car batteries. In some cases it is also suitable for testing the batteries typically used in electric bicycles, which have a nominal voltage of 26 V (more about this later on). If necessary, the voltage divider can be adjusted to provide higher resolution with a lower maximum voltage.

The current is measured directly from the voltage drop over the sense resistor R9. The battery current is not continuous, but instead controlled by a PWM signal, so the pulse signal waveform across R6 is filtered by the low-pass filter network R5/C1 (corner frequency 16 Hz) before it is fed to the ADC input on pin 2 of connector K1. The logic-level MOSFET T1, which can work directly from 5-V logic signals, is driven by the PWM output signal on pin 15 of K1 via series resistor R4. The average discharge current can be set by adjusting the duty cycle (on/off ratio) of the PWM signal. The average current of the fan, and thus its speed, is controlled in the same

way using transistor T2. The purpose of R7 is to ensure that T1 is reliably cut off when K1 is disconnected, since the battery current would be nearly 30 A with T1 fully on and the combined power dissipation of R8, R9 and T1 would be about 400 watts, which would quickly lead to toasted components. The fan current is fairly low, so there is no need for a gate pull-down resistor on T2.

The extra six-pin header K2 provides a convenient connection point for the four signals used in this circuit and signal ground. It is ideal for connecting a multimeter or oscilloscope and checking whether the circuit is behaving as it should. Otherwise K2 is not essential and can be omitted if desired.

Construction

A PCB layout for this battery tester has been designed (Figure 3), and as usual the layout file can be downloaded from the Elektor website page for this project [2] free of charge. Board assembly is actually quite easy due to the small number of leaded components, and it does not need any specific comment aside from the fact that cooling is necessary due to the high power dissipation. For the prototype, the assembled board was simply attached to a used CPU cooler, which already had a suitable fan (see Figure 4). The fan current is fairly low, so transistor T2 does

COMPONENT LIST

Resistors

- R1,R4 = 270Ω, .25W
- R2 = 8.2kΩ, .25W
- R3 = 820 Ω, .25W
- R5, R6 = 1kΩ, .25W
- R7 = 10kΩ, .25W
- R8 = 0.33Ω 50W*
- R9 = 0.1Ω 25W*



Capacitors

- C1 = 10μF 16V, radial electrolytic, 0.1" pitch

Semiconductors

- T1,T2 = IRLIZ44NPBF

Miscellaneous

- K1 = Sub-D 25 plug, PCB mount
- K2 = 6-pin (2x3) pinheader, 0.1" pitch*
- K3 = 2-pin pinheader, 0.1" pitch
- K4-K9 = Fast-on lug terminal 0.25" (6.3mm), vertical, PCB mount
- PCB # 130019-1 [3]
- USB-IO24 cable

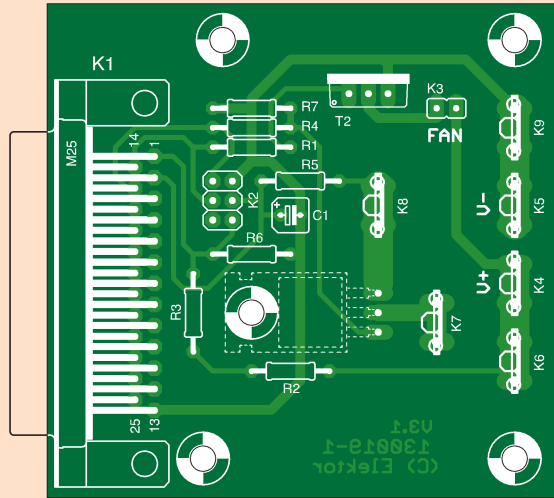

* see text

Figure 3. The circuit board with the components necessary in addition to the USB-IO24 cable.

not need a heatsink. However, the situation with T1 is quite different: cooling is mandatory here. For this reason, T1 is fitted on the solder side of the board and its leads are bent up so that they can be soldered to the PCB mounted on the heat-sink (see **Figure 5**). This means that you first have to place an insulation pad smeared with thermal paste under T1, then fit an M3 screw through the hole in the PCB from the top side with a standoff sleeve on the screw, and then bend the leads so they pass through the holes in the circuit board. After you solder the transistor leads to the board, tighten the screws that secure the PCB and T1.

The high power dissipation is also the reason why "normal" 5-watt power resistors are not adequate for R8 and R9 in particular, especially with high discharge currents. The power dissipation of R8 is more than 20 watts at the (nominal) maximum discharge current of 8 amps, while R9 has to be able to handle 6.4 watts under this condition. High-power wire-wound resistors in metal cases (see the components list) were used in the prototype. They were screwed onto the side of the heat sink.

Test and operation

After assembling and checking the PCB and attaching it to a heat sink, it's time to plug the USB-IO24 cable into the computer and connect

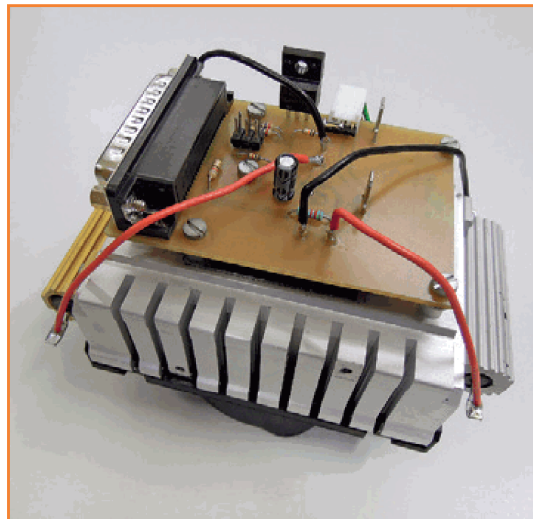

Figure 4. Prototype of the battery tester. The board and components T1, R8 and R9 are mounted on a used CPU heat sink.

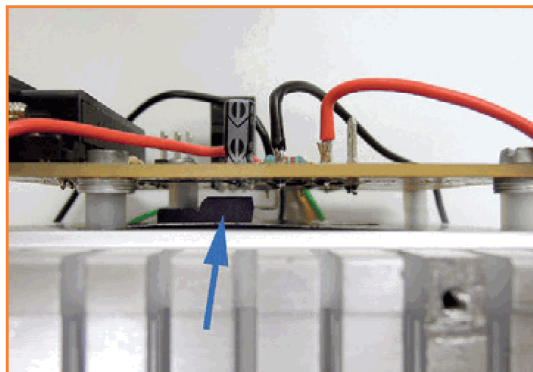

Figure 5. T1 (blue arrow) is mounted on the heat sink below the board with a standoff sleeve.

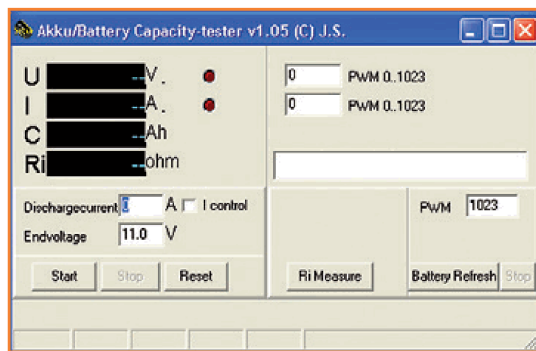

Figure 6. Screenshot of the user interface of the battery tester software.

the other end to the batter tester module. When the USB cable is connected to a Windows system for the first time, a driver has to be installed. With modern versions of Windows and an Internet connection, this is simply a matter of a couple of mouse clicks. Next you have to install the software on the PC in order to check out the tester. The source code and the executable (KapTester.exe) are available for download at [3].

Figure 6 shows a screenshot of the KapTester user interface in normal operation with a 12 V battery connected. For board testing, you can start by applying low voltages (in the range of 0 to 5 V) to the analog inputs on K2. For the voltage input, KapTester should show a reading equal to ten times the voltage applied to pin 4, and for the current input the reading should be 10 A per volt applied to pin 5. The voltages measured with a multimeter on pins 1 and 3 should also match the voltages corresponding to the indicated PWM values. With the PWM values of 166 and 1,023 as shown in the screenshot, the output voltages should be approximately 0.8 V and 5 V. If the multimeter reading is not stable, you can connect a low-pass network (consisting of a 1 kΩ resistor and a 10 μF capacitor) between the output pin and the meter probe.

If everything checks out okay, you can connect a battery to the circuit. To be on the safe side, it is a good idea to connect an incandescent auto lamp bulb (rated at 20 W to 50 W) in series with the battery leads the first time you do this, instead of connecting the battery directly. If anything is wrong, the lamp will simply light up. With the specified component values and a CPU heat sink, the circuit is suitable for a maximum discharge current of 8 A, which corresponds to a total power dissipation of slightly more than

100 W in the worst case. To start a measurement session, specify the desired discharge current and enter a realistic value for the battery voltage at the end of the discharge cycle, and then click Start. The software will then automatically set the specified current and log the battery voltage and the current drawn from the battery. The capacity is calculated from the total measured current, and the battery voltage versus time during the discharge cycle is displayed as a curve. The measurement session is ended when the specified end voltage is reached.

Along with the battery capacity, the internal resistance of the battery can be measured as a relevant parameter. This is done by first measuring the voltage before the load is applied, and then briefly setting the PWM value to 1,023 for the maximum possible current, which is slightly more than 30 A with a 12-volt battery. The voltage and current are then measured under this condition. After this, the no-load voltage of the battery is measured again. The internal resistance can then be calculated using the formula:

$$R_i = ((U_{\text{before}} + U_{\text{after}}) / 2 - U_{\text{load}}) / I_{\text{load}}$$

Battery refresh, which is not a battery parameter, is a useful extra function. This involves generating a high current pulse every 10 seconds, which is intended to loosen any sulphate deposits in lead-acid batteries. The strength of the current pulse can be set using a PWM value.

More options

The combination of the circuitry and the software is designed for lead-acid batteries with 12 V nominal voltage and a maximum load current of 8 A. Batteries with higher voltage and higher discharge currents can be connected to the circuit without any hardware changes. However, you must keep an eye on the resulting power dissipation and provide better cooling if necessary, and you must also modify the software and adjust the setting ranges and other parameters. We strongly recommend reading the article on the USB-IO24 cable for information in this regard.

With a value of 0.1 Ω for R9, it is theoretically possible to measure currents up to 50 A. However, currents in this range are only possible with higher-voltage batteries due to the overall resistance of R8, R9 and T1. If you utilize the full rated capacity of R8 (50 W), the limit is approx-

imately 12 A, but even with a 12 V battery this will require better cooling. You will also have to use resistors with high power ratings and beef up the tracks on the PCB that carry high current. The FET specified for T1 is near the end of its tether at 20 A.

If you want to test batteries for electric bikes and go-karts, you are usually dealing with lithium batteries with a nominal voltage of 24 V or 36 V. The circuit is directly suitable for this, with one exception: the measuring range extends to 50 V, but the fan cannot handle this voltage. The options here are to use a fan with a suitable rated voltage, to insert a series resistor in the fan lead, or to power a standard 12 V fan from a separate power supply instead of directly from the battery. The battery tester is not suitable for 48 V batteries for two reasons: the measuring range is not sufficient, and the rated voltages of T1 and T2 are too low for this purpose.

All of this means that if you want to adapt the circuit and the software to your own purpose, you should know exactly what you are doing. In particular, you have to pay attention to the power dissipation. However, if all you want to do is to test normal 12 V lead-acid vehicle batteries, you only need to exercise your soldering skills and no programming at all is required with the ready-made .exe file.

(130019-I)

Internet Links

- [1] www.elektor.com/120296
- [2] www.elektor-projects.com/project/battery-tester-with-usb-io-24-cable-130019-i.12920.html
- [3] www.elektor.com/130019

Advertisement

Create Complex Electronic Systems in Minutes Using Flowcode 6

FLOWCODE 6

Design → Simulate → Download



Flowcode is one of the World's most advanced graphical programming languages for micro-controllers (PIC, AVR, ARM and dsPIC/PIC24). The great advantage of Flowcode is that it allows those with little experience to create complex electronic systems in minutes. Flowcode's graphical development interface allows users to construct a complete electronic system on-screen, develop a program based on standard flow charts, simulate the system and then produce hex code for PIC AVR, ARM and dsPIC/PIC24 microcontrollers.

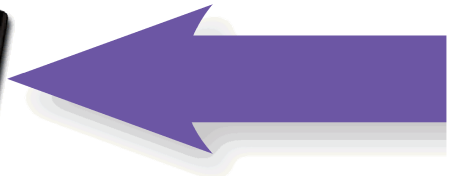

New in Version 6:

- Component Library Expansion;
- Improved Simulation;
- New Test Features;
- 3D Design Environment;
- Third Party Instrument Support;
- Dashboard HMI Components;
- And More!

Further Information and Ordering at www.elektor.com/flowcode



FRONT PANELS & HOUSINGS

Cost-effective single units and small production runs

Customized front panels can be designed effortlessly with the Front Panel Designer. The Front Panel Designer is available free on the Internet or on CD.

- automatic price calculation
- delivery in 5–8 days
- 24-Hour-Service if required



Sample price: 34,93 € plus VAT/shipping

Schaeffer AG · Nahmitzer Damm 32 · D-12277 Berlin · Tel +49 (0)30 8058695-0 Fax +49 (0)30 8058695-33 · Web info@schaeffer-ag.de · www.schaeffer-ag.de

USB

Add USB to your next project. It's easier than you might think!

DLP-USB1232H: USB 2.0 UART/FIFO

HIGH-SPEED

480Mb/s



Only \$28.95!

- Multipurpose: 7 interfaces
- Royalty-free, robust USB drivers
- No in-depth knowledge of USB required
- Standard 18-pin DIP interface; 0.6x1.26-inch footprint

DLP-IO8-G

8-Channel Data Acquisition

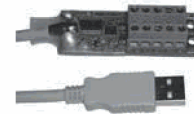

Only \$29.95!

- 8 I/Os: Digital I/O
Analog In
Temperature
- USB Port Powered
- Single-Byte Commands

DLP-IOR4

4-Channel Relay Cable

DLP-TH1b

Temp/Humidity Cable

DLP-RFID1

HF RFID Reader/Writer

DLP-FPGA

USB-to-Xilinx FPGA Module



www.dlpdesign.com

THE GREAT HOLIDAY SALE!

Shop and save at www.cc-webshop.com

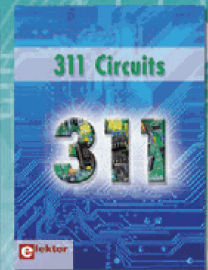
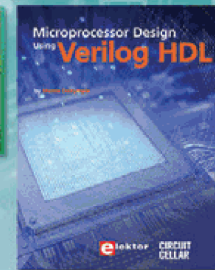
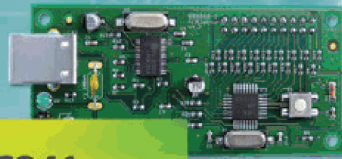

20% OFF 20% OFF 20% OFF

20% OFF



AP CIRCUITS
PCB Fabrication Since 1984

As low as...

\$9.95
each!

Two Boards
Two Layers
Two Masks
One Legend

Unmasked boards ship next day!

www.apcircuits.com



Throw off the 8-bit ball and chain!

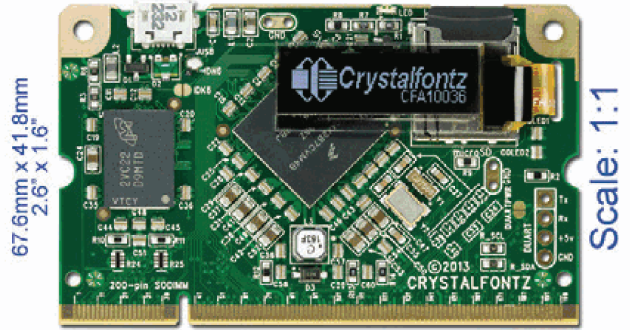

CFA10036 ARM9 + Linux SOM

- fast: 454MHz ARM9
- deep: 128/256MB
- wide: 91/126 GPIO
- μSD: 4GB to 64GB
- USB/UART/SPI/I2C
- debug/status OLED
- Linux mainline kernel
- 6xADC/8xPWM/CAN
- \$71@Q1 to \$48@Q500

Get your project to market fast: lay down a standard SODIMM connector, snap in a CFA10036 System-On-Module and you instantly have access to tons of GPIO and the power of Linux. Leave the 8-bit dark ages behind.

CFA920-TS

- This tiny, touch-enabled embedded Linux PC is powered by the CFA10036
- 800x480 color TFT
 - resistive touch screen
 - 10/100 Ethernet + USB
 - 24 GPIO on 0.1"
 - 79 more GPIO on 1mm
 - 6-channel accel+gyro
 - \$140@Q1 to \$105@Q500

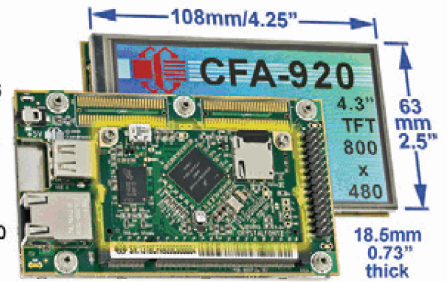

Crystalfontz

www.crystalfontz.com +1 509 892 1200

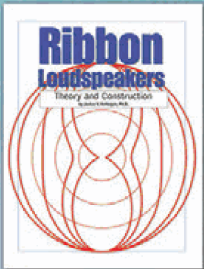
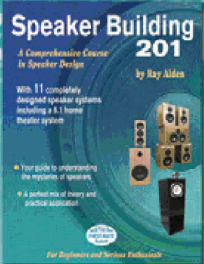
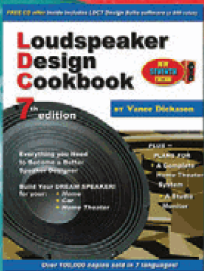

20% off

Coupon code:
HOLIDAY13

circuit cellar circuit cellar circuit cellar

Enter BeagleBone Black

Good Dog or Pi Eater?

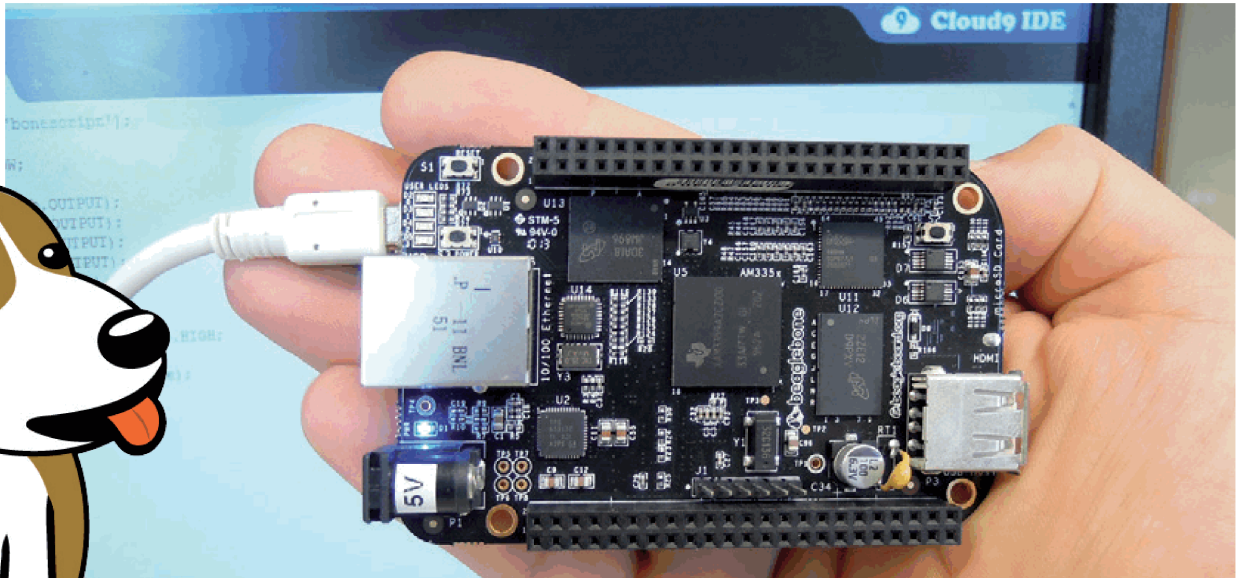

Yet another platform has been released to the embedded audience: the BeagleBone Black. Recently we (finally) got one on our workbench. It looks like a very promising platform with powerful hardware and a lot of potential. Does it outperform the Raspberry Pi?

By
Thijs Beckers
(Elektor Editorial)

The BeagleBone Black (BBB) was launched earlier this year. This “1GHz 512MB open-hardware embedded computer with On-board 2GB eMMC flash” is the successor of the successful BeagleBone credit-card-sized Linux computer. It boasts a Sitara AM3359AZCZ100 ARM Cortex-A8 processor capable of 2,000 MIPS, an SGX530 graphics engine capable of 20M polygons/s, 512 MB DDR3L SDRAM running at 800 MHz, 10/100 Mb Ethernet, USB 2.0 host and client ports, μ SD card slot, μ HDMI, 65 digital and 7 analog inputs, 8 PWMs, 4 timers, 4.5 serial UARTs, 2 I²C ports, 2 SPI ports, and is even cheaper than its predecessor—at about half the price of the BeagleBone the BBB costs only \$45 (around €45 in Europe), which is quite competitive looking at the price of its nearest competitor the Raspberry Pi.

From our IT department we confiscated a nice television set with HDMI input—a Sony KDL-

32EX650. Then we ordered a μ HDMI to HDMI cable, tracked down a mouse and plugged it all in. Very conveniently, our TV was also equipped with a host USB port, which we used to power the BBB.

BBB currently comes with the Linux Ångström distribution preinstalled on the internal eMMC flash memory, and boots right into the GUI (Graphical User Interface). So right out-of-the-box you can start using it in stand-alone mode, unlike the RPi, which needs an SD card with the OS copied onto it.

Sure, the BBB can also be connected to your Windows PC for embedded development work. This procedure is almost as smooth as baby’s buttocks. After plugging BBB into a free USB slot, Windows Autoplay opens. Select *View files* and open *START.htm*, like it says on the little note

inside the box the BBB came in. A web browser opens, and drivers for BBB are easily installed from the (off line) webpage shown here (1). All the necessary files are on the BBB, which looks just like a USB stick you plugged in, so no Internet connection is necessary. Despite the security warnings (2)—we got four of them!—everything turned out great and the drivers install without a hitch (3). The website even tracks your progress (4). Now you're ready to connect to the BBB webservice, located at 192.168.7.2 (use Chrome or Firefox). Developing your own application is 'easy'. The Cloud9 IDE (5), accessible by typing 192.168.7.2:3000 in your web browser's address bar or by clicking the link on the 'BBB Home page' (the page that opens from the BBB webservice), runs in your web browser and doesn't need to be installed on your PC. It makes use of the BoneScript JavaScript library, which simplifies learning how to perform physical computing tasks on the BBB. Several examples are available that pave the way to developing your own application. Though the learning curve still is quite steep, and having programmed C or Java before sure helps a lot.

Several shields... sorry!, *Capes* are available. Basically these are daughterboards the BBB 'carries' on its expander busses and add functionality. Some examples are: 3D Printer, CAN bus, 7" LCD touchscreen, VGA, Weather, Camera, Audio, Radar and many more. Many of the 'old' Capes designed for the (first) BeagleBone are compatible with BBB. Just keep an eye on whether the BBB Linux distro needs an update. We wanted to try our BeagleBone LCD7 Cape rev. A2, which we had laying around from the BeagleBone Camera Demo Kit. According to [1] it should be compatible with BBB, but you need to make sure your Ångström version is 2013-06-20 or up to prevent damaging(!) your BBB. Ours was dated 2013-06-06 of course, so we needed to update.

Updating to the latest Linux distribution is easy, but kind of uncertain as there is no feedback on the process. We updated our BBB using the microSD card-method: download the latest image from [2], use 7-zip [3] to extract the image, use Diskimager [4] to write the extracted image onto a microSD card (which must be at least 4 GB), power BBB with a 5 V/1 A wall wart keeping S2 pressed down until one or more User LEDs come on (microSD card inserted, Ethernet and USB devices unplugged!). If you follow this procedure *exactly(!)*, the onboard eMMC is being flashed with the image that's on the microSD card. There's no feedback on the (HDMI-)display, just the User LED array flickering, but it's also doing that when BBB is connected to a USB-port...

With the update finally done (it takes about 40 minutes), the BBB happily booted into the new version (6, yes that is the BBB in front of it!).

Then we plugged BBB onto the LCD7 Cape, powered it up and waited for the GUI to appear... which it didn't. Actually, nothing happened on the screen. It wasn't until we unplugged the Camera and Weather Cape from the LCD that BBB booted. Flawlessly! (7) Including a calibration sequence for the touch sensitive screen. Browsing for compatible Capes, it turned out both the Camera and Weather Cape

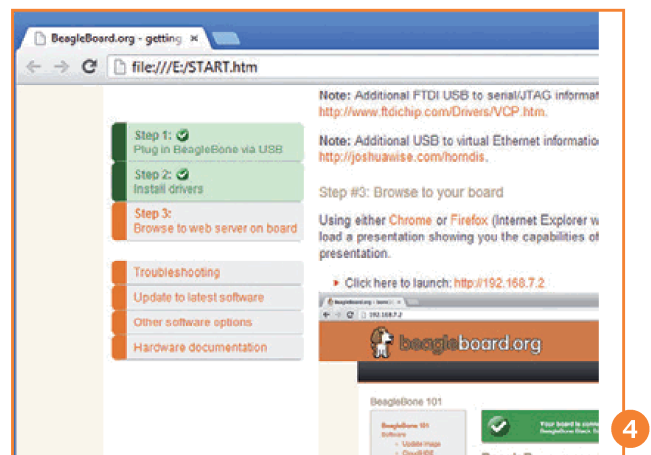
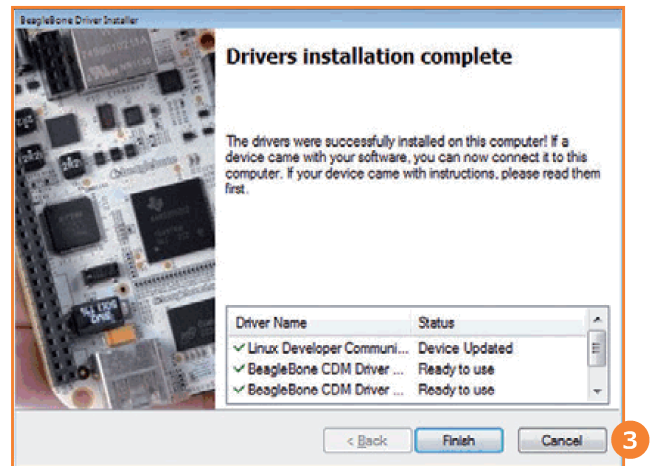
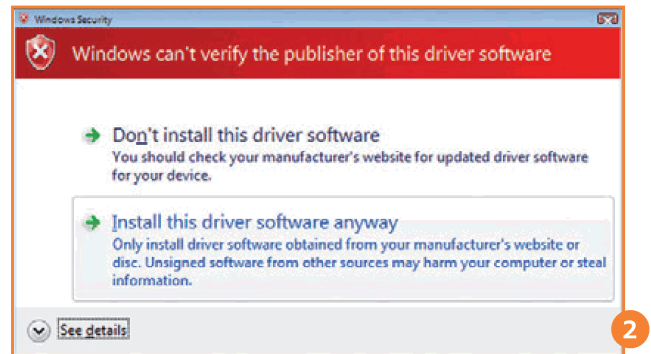
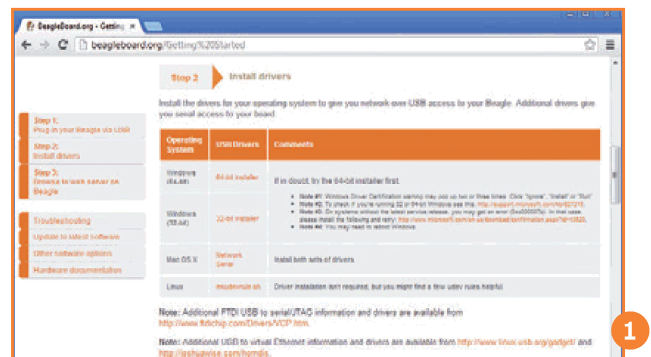

Projects

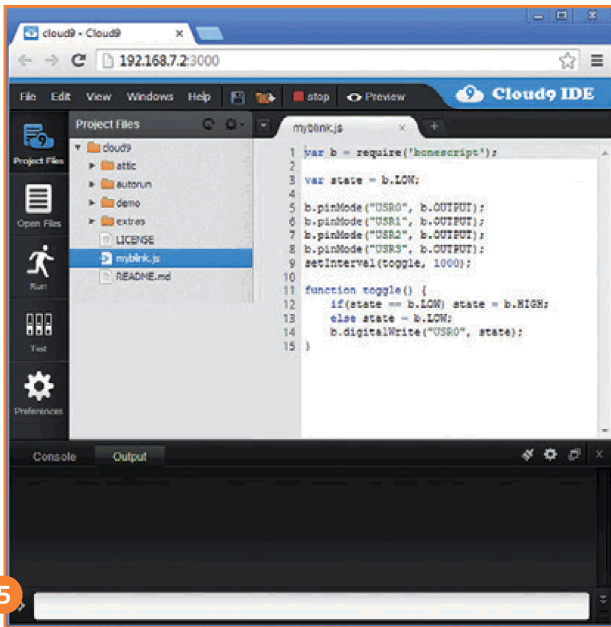

5

were not (yet) compatible with the BBB. Oopsy! Luckily nothing was damaged, so all's well.

Our impression of the BBB is highly positive. What you get for \$45 is just astounding. Though it seems RPi is more suitable for making your own home theater media player, the BBB looks more powerful and offers a ton of I/O's and all the connectivity you could wish for (although you're going to need a USB hub to connect more than one USB device, i.e. a keyboard and a mouse, as it's equipped with only one USB host port).

To summarize: Raspberry Pi is for starters and has the largest community at this time, BeagleBone Black is a more serious system and a bit harder to master, but its hardware tops that of the RPi considerably. And its user community at [5] will happily help you if you run into troubles with your BBB.

As an aside: we are working on a GnuBlin Cape, which lets you connect the GnuBlin extension boards to the BBB. That should keep the dog amused!

(130279)



6

Internet Links

- [1] <http://beagleboardtoys.info>
- [2] <http://beagleboard.org/latest-images>
- [3] www.7-zip.org
- [4] <https://wiki.ubuntu.com/Win32DiskImager>
- [5] <http://beagleboard.org/Community>

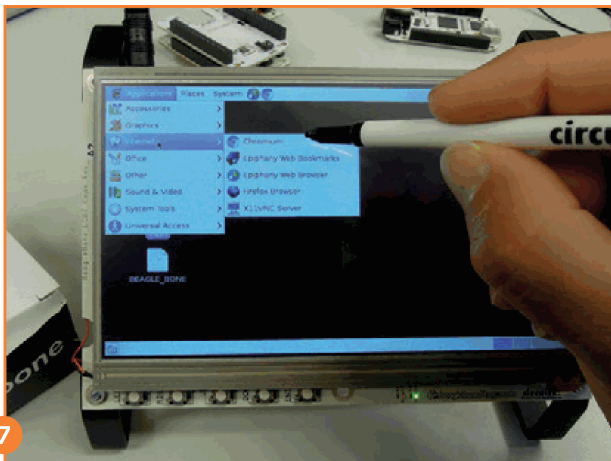

7

What would YOU do with a BeagleBone Black?

Would you build a media center, like so many have done with the Raspberry Pi? Would you use it as an affordable embedded development board? Or as a security system in your car or—again— as a mobile media system? Or perhaps a simple temperature and humidity monitor for your tomatoes—remotely accessible of course, or make it the *brains* of a robot? Maybe you already developed your application and would like to share it with our community? Actually, we're looking for authors who let that Pi burn (in the oven) and threw that Beagle a Black Bone, so if you think your nifty \$45 mini computer application is not only of interest for you, please feel free to contact us and with some luck your BBB design will shortly be known among 250,000+ electronics enthusiasts...

Starting place: www.elektor-labs.com.

Join the Elektor Community

Take out a GOLD Membership now!



Your GOLD Membership contains:

- 8 Regular editions of Elektor magazine in print and digital
- 2 Jumbo editions of Elektor magazine in print and digital (January/February and July/August double issues)
- Elektor annual DVD-ROM
- A minimum of 10% DISCOUNT on all products in Elektor.STORE
- Direct access to Elektor.LABS
- Direct access to Elektor.MAGAZINE; our online archive for members
- Elektor.POST sent to your email account (incl. 25 extra projects per year)
- An Elektor Binder to store these 25 extra projects
- Exclusive GOLD Membership card



ALSO AVAILABLE:

The all-paperless GREEN Membership, which delivers all products and services, including Elektor.MAGAZINE, online only.



Take out your Membership now at www.elektor.com/members



The FlowStone of Wisdom

More than a visual programming tool with a pretty (inter)face

By **Clemens Valens**
(Elektor.LABS)

Visual programming implies creating programs by manipulating functions graphically rather than by typing in text. In many visual programming languages (VPLs) screen objects (often boxes) represent functions interconnected by arrows, lines or arcs representing data relations. A well-known VPL is LabVIEW, but there exist many more. One of them is FlowStone, a VPL with a twist.

Flowstone, a sheet-like deposit of calcite or other carbonate minerals, is formed where water flows down the walls or along the floors of a cave. In FlowStone a program is formed by stacking layers of functions through which data flows. You may be able to formulate it a little better, but you get the idea of the analogy.

It all started some ten years ago with SynthMaker, an audio programming application that lets its user create virtual instruments, effects and controller plugins without the need to write a program. These instruments and effects can be used for making music using for instance Virtual Studio Technology (VST) compatible recording software. After a few years SynthMaker got a little sister called FlowStone. The baby sister turned out to be very demanding and she started to absorb her elder twin sister, the feat completed when she turned version 3 in November 2012. The medically inclined might speak of a case of *Vanishing Twin Syndrome* (VTS).

In FlowStone a program is drawn on a 1024 x 1024 grid called the Schematic. Function objects, or

components as they are called, are placed on the schematic. Components have connectors for receiving and/or sending data. The connections between the components — the links — are represented by lines that usually run from an output connector (start) to an input connector (end). Several types of connector are available for different types of data, each identified by a unique symbol and color. Schematics quickly become complex and so sub-circuits can be turned into modules for use as components in a schematic.

A module can have a graphical front panel with knobs and buttons and other controls. Once the application is ready, it can be exported as a stand-alone (native) PC application that runs without FlowStone or a virtual machine.

The FlowStone user interface is pretty slick and a lot of effort has gone into making components easily accessible and making navigation through the design fast. The component library — toolbox — can be searched in many ways using the component browser's filters, so if you really cannot

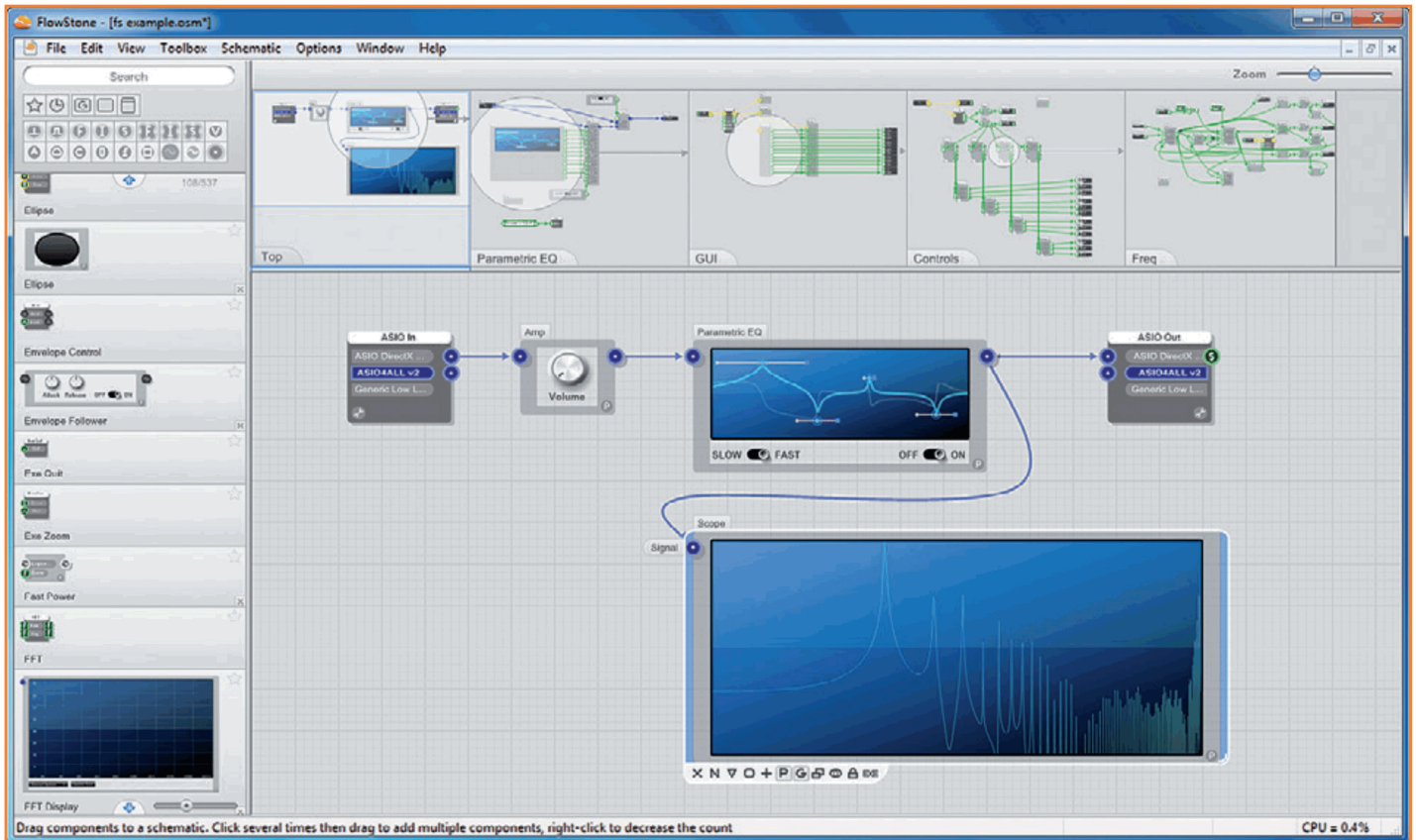

find the component you are looking for, then it probably does not exist.

The schematic grid is quite large and a special navigation window is available for quickly scrolling and panning through your design. It also features a thumbnail zoom view providing an overview of the design together with detailed views of some modules. The life of the experienced FlowStone user is made even easier by tons of shortcuts. Furthermore, a detailed user manual is available for download.

Looking through the toolbox you will notice a lot of audio functions and signal processing components, but more generic functions like text handling or line drawing are available too. Highly interesting also are the external hardware components that make interfacing to for instance a Wiimote (the remote control of a Wii game console), an X10 network (a popular home automation protocol) or Phidgets (low-cost USB building blocks for sensing and control) very easy. Special FlowStone hardware exists too, notably the FlowBoard DAQ, a board sporting eight analog

inputs, sixteen digital inputs and sixteen digital outputs. FlowStone now also supports communication through HID devices (see inset).

Creating a design in FlowStone is very easy (I did not say *working* design); you just drag and drop components from the toolbox onto the schematic (other ways of placing components are available too). If you place a component close to another with compatible inputs and/or outputs, the connecting links can be drawn for you, speeding up your work. When you select a component in the schematic a short help text is shown for its connectors, making it easier to understand their purpose.

Manually connecting components always starts at an output and ends at an input. Usually the outputs are on the right side of a component and the inputs on the left. When dragging a link to a component, only the connectors compatible with the data type transported by the link will be accessible.

Links do not always have to be drawn, they can

Figure 1. A FlowStone schematic showing simple audio processing using a parametric EQ and a display to plot the FFT of the resulting signal.

Control your own hardware

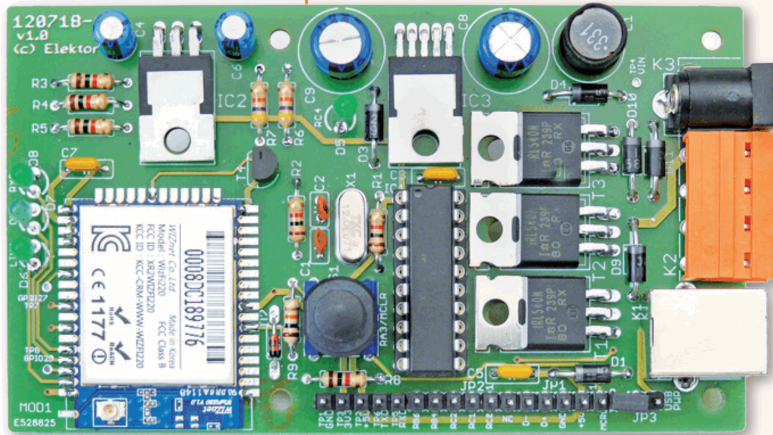

The latest version of FlowStone is capable of communicating with HID devices, meaning you can develop your own HID board and control it from FlowStone. The Elektor Wi-Fi Controller Board [2] for instance is such a compatible board. Because it has a bootloader it is a perfect platform for developing FlowStone controlled applications. Create some sort of music application like a synthesizer or a complicated sound processing tool and use the Wi-Fi Controller Board to create accompanying light effects or make a robot dance. Or use FlowStone for your hi-tech scientific data acquisition and processing application and control the physical process with the Wi-Fi Controller Board. I have given it a try and it works fine. To give you a head start my C18 project can be downloaded (for free, of course) from [3].

also be wireless. Such links are similar to the net labels found in schematic capture programs with one subtle difference: wireless outputs can only send to modules on a lower level in the hierarchy.

FlowStone recognizes more than 30 data types, divided in three categories: streams, events and triggered. Streams are continuously flowing data streams like audio or video samples. Triggered types and events are signals caused by events. The difference between these two categories is that triggered types only signal that something has changed whereas events (can) carry data. Also, events are scheduled, meaning that they only occur at times specified by the programmer. Interestingly, streams come in two flavors, monophonic (mono) and polyphonic (poly), and the way they behave is quite different. As the user manuals states: *"Poly is only used for audio applications where sound signals are generated from MIDI notes. If you're not generating audio in this way then you can ignore Poly completely."*

Even though FlowStone is a graphical programming language, it is easy to write (part of) a program in the traditional way using the Ruby programming language. This of course violates the graphical programming paradigm, but it is a logical option as some functions may be easy to draw whereas others may be more quickly implemented by writing an algorithm.

Unfortunately, space restrictions for this article do not allow an in-depth review of FlowStone and all it has to offer, which is plenty. If you want to play around with the tool yourself, I suggest you download the free demo version from [1]. If you happen to own a copy of the latest version of the digital audio workstation (DAW) FLStudio then you already have FlowStone as it is part of the package (older versions of FLStudio shipped with SynthMaker).

(130064)

Internet Links

- [1] Flowstone main page:
www.dsrobotics.com/flowstone.html
- [2] Wi-Fi Controller Board:
www.elektor.com/120718
- [3] Downloads for this article:
www.elektor.com/130064

engineering electronics
 DISCUSS **embedded**
 design tips tutorial software
 engage **engineering** tools
 contests system **audio** business
networking **media** COMMUNITY
social media talk
 data information
 product news

mobile

projects

Want to talk to us directly?
 Share your interests and opinions!
 Check out our New Social Media
 Outlets for direct engagement!

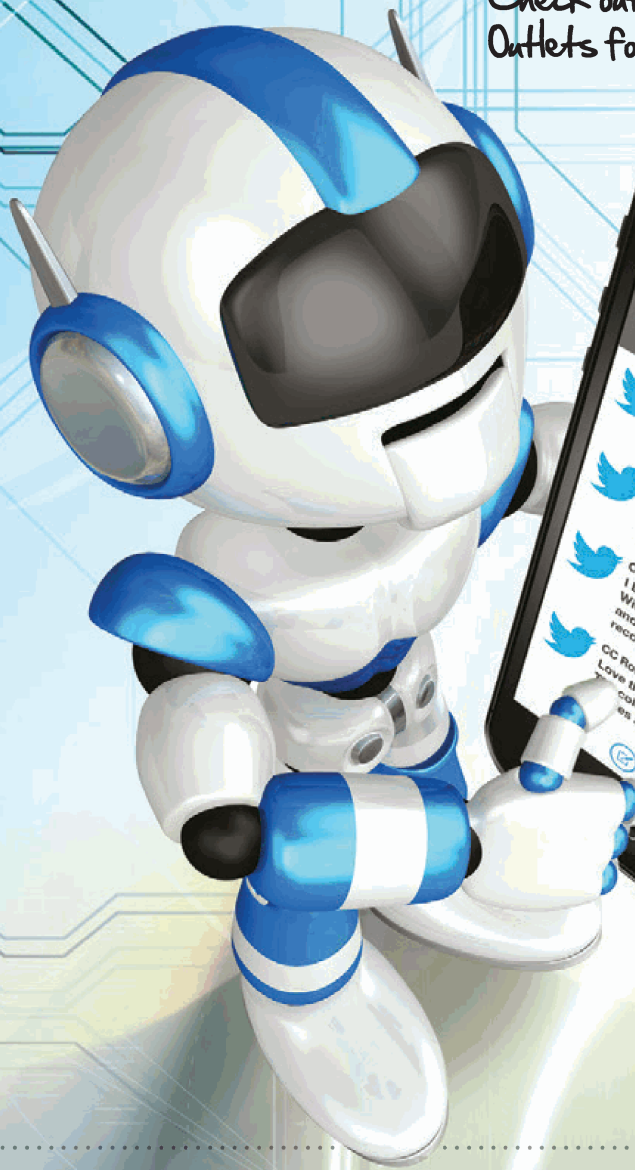

CIRCUIT CELLAR / AUDIOXPRESS / ELEKTOR

Joule Robbin' Hood

Powering a grow lamp from nearly empty batteries

By Rolf Blijleven (Netherlands)



Even if your camera, mouse or keyboard says that its batteries (AA or AAA) are flat, this does not mean that they are exhausted. In many cases there's still quite a bit of juice left in the batteries, which you can put to good use. The circuit described here is based on the famous Joule Thief [1] and is guaranteed to suck batteries dry.

The Joule Thief lets you use the leftover energy in a battery. It comprises the circuitry outside the dashed line in **Figure 1**. Transformer T consists of two coupled coils, each with approximately 20 dual windings of 0.15-mm (AWG 34) enameled copper wire on a toroidal core, connected in opposite phase. It's easy to wind this trans-

former yourself on a small ferrite core with an inside diameter of 5 to 8 mm and a height and thickness of 5 mm. The circuit forms an oscillator with sufficient amplitude to switch the transistor on and off on each cycle and light up an LED.

The idea for the present version came when I was watching a television program about modern greenhouse cultivation, where LEDs are being used more and more. Plants do not need green light. In fact, the reason they are green is that they reflect green light. However, they do need blue and red light. Blue light is mainly necessary for germination and for forming sturdy leaves and stems, while red light is necessary for blossoming. So I thought: why not use a Joule Thief to power a grow lamp? The results exceeded my expectations (see [2] for more details). This marked the birth of Joule Robbin' Hood, which steals from the rich battery and gives to the poor plants.

The rest of the circuit is fairly straightforward. The LDR (with a dark resistance of 100 kΩ) and resistor R2 form a voltage divider in combination with R4. The resistance of the LDR is low when it

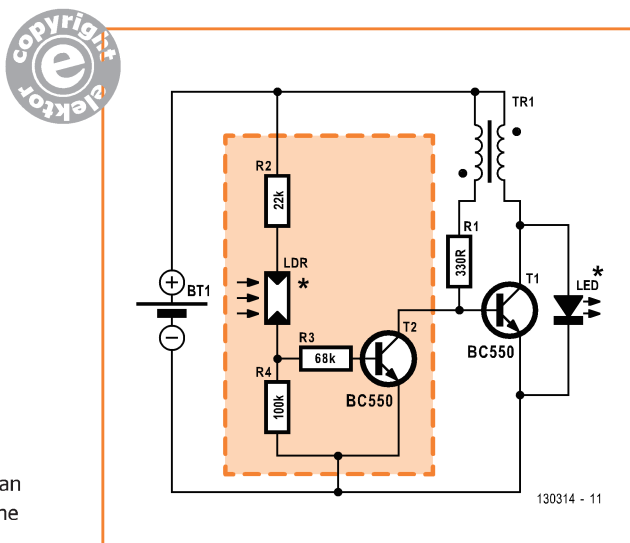

Figure 1. Joule Robbin' Hood is an expanded version of the Joule Thief.

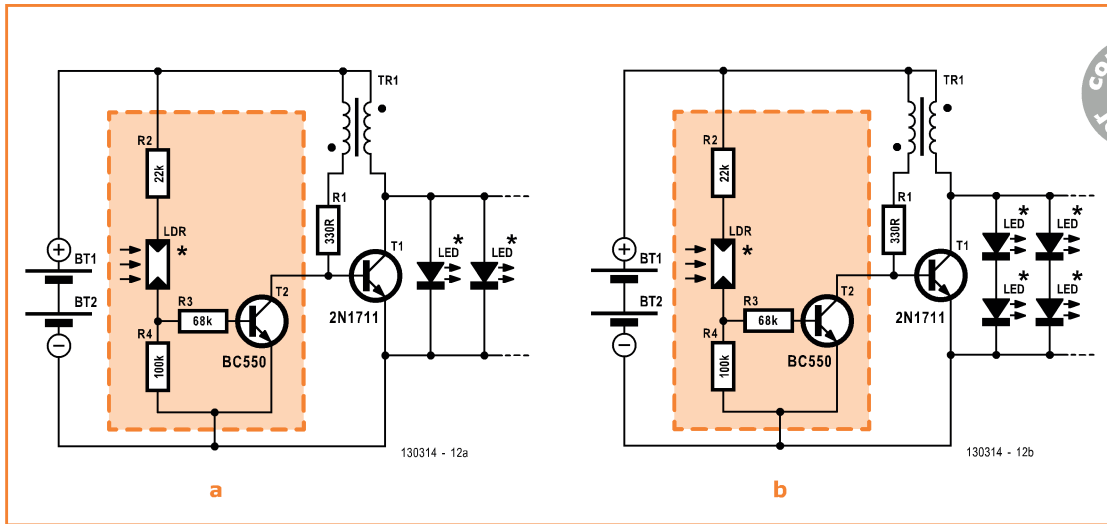

Figure 2. Two versions of the circuit: (a) with multiple LEDs connected in parallel; (b) with series pairs of LEDs connected in parallel.

is illuminated, so the resistance of R4 dominates and the voltage across R4 is relatively high. This causes transistor T2 to conduct and switch off T1. When it's dark the situation is exactly the opposite—then the LDR and R2 dominate, so T2 is off and T1 can conduct. There's no need for light from the LEDs when full natural light is available, so resistor R3 reduces the base current of T2 to the point that it just barely conducts. After all, we don't want to have T2 drain all the energy from the battery; as much as possible should go to the LEDs.

After a bit more experimentation I discovered that with two nearly empty batteries connected in series and a transistor with a bit higher power rating for T1 (e.g. a 2N1711), it's possible to power up to 10 LEDs in parallel for two days (**Figure 2a**). If you connect pairs of LEDs in series and then wire these pairs in parallel (**Figure 2b**), you would expect them to go dark much sooner than single LEDs in parallel, but there is actually very little difference in operating time or brightness. This means that for a grow lamp you can connect pairs of red and blue LEDs in series and then connect several of these pairs in parallel, which is easier to wire up than separate strings of red LEDs and blue LEDs.

Be sure to use superbright LEDs for this application, as mentioned below. Avoid looking directly at the LEDs while experimenting, since they are rather bright. There are lots of possible variations on this circuit, and it is easy to build with point-to-point wiring or on a piece of prototyping board.

(130314-1)

Suitable LEDs:

- superbright red (e.g. Sloan L5-R52U)
- superbright blue (e.g. Kingbright L-7113QBC-G; Newark/Farnell # 2080007).

Internet Links

- [1] http://en.wikipedia.org/wiki/Joule_thief
- [2] <http://rolfblijleven.blogspot.nl/2013/04/led-groeilamp-op-bijna-lege-batterijen.html> (in Dutch)





DesignSpark Tips & Tricks Day #6: after the layout

By **Neil Gruending**
(Canada)

Today we're going to use the DesignSpark online BOM and PCB quoting tools to find out how much it would cost to build our example project. These tools can be a great time saver.

Edit details	<input checked="" type="radio"/> Ignore row	<input type="radio"/> Accept	<input type="radio"/> Accept
4	Requested		
Man Part No.	NPN MMBT3904	MMBT3904LT1G	MMBT3904LT1G
Manufacturer		ON Semiconductor	ON Semiconductor
RS Stock No.		545-0343	545-0343P
Unit Quantity	2	50	50
RoHS		<input checked="" type="checkbox"/> RoHS	<input checked="" type="checkbox"/> RoHS
<input type="button" value="View full product details"/>			

Figure 1. Best matching of the generic type code 'NPN MMBT3904' to RS Components part numbers.

BOM Quotation

In our last installment we generated a bill of materials (BOM) as a spreadsheet that could be used to manually order the parts we need for the board. Some supplier websites will let you upload your BOM to order your parts, but DesignSpark cuts out the intermediate steps and connects to the RS Components website for you. The website doesn't work worldwide yet, but I hear that they're working on it. For this article I set my locale to the United Kingdom (Settings → Preferences menu) since the website connection doesn't work for Canadians yet.

So let's see what will happen when we click on the BOM Quote since the components I created didn't have any RS part numbers. Once you click on the button DesignSpark will run the built in BOM report using the fields that it knows about: Reference Designator, Quantity, Component Name, Component Value, Package Name,

Figure 2. Here we find the RS Components part numbers for 3k6 (3.6 kΩ) and 3k9 (3.9 kΩ) SMD resistors.

Edit details	<input checked="" type="radio"/> Ignore row	<input type="radio"/> Accept	<input type="radio"/> Accept
2	Requested		
Man Part No.	0805 100 5%	RS-0805-3k6-5%-0.125W	RS-0805-3k9-5%-0.125W
Manufacturer		Viking Tech Corpor...	Viking Tech Corpor...
RS Stock No.		713-6982	713-6985
Unit Quantity	1	1	1
RoHS		<input checked="" type="checkbox"/> RoHS	<input checked="" type="checkbox"/> RoHS
Description	Resistor	0805 Resistor, 0.1...	0805 Resistor, 0.1...
Price		£8.63	£8.63
Units		1 Reel of 5000	1 Reel of 5000
Goods Price		£8.63	£8.63
Availability		In stock for next w...	In stock for next w...

Manufacturer, Manufacturer Part Number, RS Part Number and the Component Description. Note that the Package Name field is a separate field in the schematic symbol and not the PCB footprint name. Next DesignSpark will log you into the RS website with your ModelSource ID so that the BOM can be uploaded to the RS website. The website will then do its best to match the component fields in the BOM to RS part numbers. When the RS part number field is blank, the website will propose its best matches.

For example, **Figure 1** shows the proposed matches for the MMBT3904 in our design. There you can see that the website is using the Component Name "NPN MMBT3904" as the main search term and that the website is proposing its closest matches. If you click on the View full product details arrow on the bottom row the table will expand to show more details like the component cost. In this case we'll accept the first match because it's the correct part number. **Figure 2** shows another example.

This time the website couldn't find an appropriate match which leaves a couple of options to find the correct part. If you have a RS account then you can click on the Edit details link to modify the part information, but you will need to do this every time you upload a BOM that uses this part. For that reason I like to correct the part information in DesignSpark's libraries instead.

The manufacturer part number "0805 100 5%" that was used by the website was actually the Component Name for R3 which means we should rename it. First, open the Library Manager and then navigate to the 100R component in the resistor library. Here you will find a Rename button so that you can rename the part "0805 100r 5%".

The next step is to tell DesignSpark to reload the part parameters for R3 from the library. Normally you would use the “Update Components → All Components” command in the Tools menu or right clicking on R3 and selecting “Update Component”. But since we’ve changed the Component Name we’ll need to replace R3 with the updated component by going into the Component Properties and clicking the Change button, see **Figure 3**. The “Change Component” window will then open so that you will be able to select our new resistor from the library. Now when you click the “BOM Quote” button the RS website will recognize the modified 100R resistor.

Some parts like the LED will be difficult to match with just the component name so you could set the RS part number in the “RS Part Number” field instead. Then just update the component instead of changing the component. Once all the components have been updated then you can create an order pad by pressing “Add accepted items to order pad” where you can see the total costs and place an order.

PCB Quotation

We’ll also need a printed circuit board if we’re going to make our design so let’s try using DesignSpark’s PCB quoting function. As part of the quoting process, DesignSpark will check if you’ve ran a design rule check (DRC) on the board and that it’s within the design limits for the service. I had problems using Chrome as my default browser when trying the quotation function so I used Internet Explorer for the rest of the quotation process.

If you try and quote the circuit board as is DesignSpark will warn you that the board is too small because the minimum size for quoting is 30 mm x 30 mm and our board is 20 mm x 20 mm. If you ignore the error and try and get a quotation anyways the quotation website will fail. We will have to panelize our board to make it large enough to meet the minimum PCB size requirement.

Panelizing a circuit board refers putting multiple copies of the circuit board onto a larger PCB panel for manufacturing. This is how a circuit board manufacturer produces circuit boards, but there is a point where it becomes cost prohibitive to cut out smaller boards out of large panels. So what we will do for our board is to duplicate the

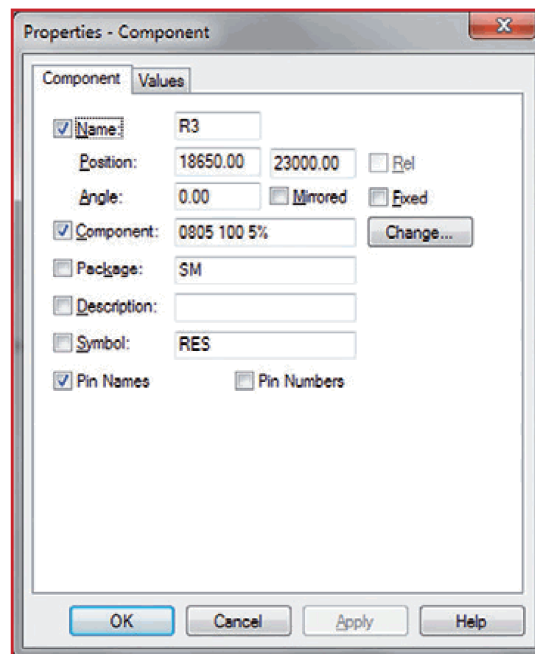

Figure 3. The component renaming window.

board four times to make it 43 mm x 43 mm instead as a 2 x 2 array of boards with 3 mm between them. The extra 3mm gives you room to cut out the boards.

DesignSpark can’t automatically panelize our board for us but it is possible to do it manually by selecting the entire board, copying it and then pasting it back into the PCB file. Just make sure that you choose to not to merge the +5 V and GND nets when DesignSpark asks. Unfortunately DesignSpark will also automatically increment all of the reference designators so that they don’t conflict with the rest of the boards. The only way to fix this is to manually edit but this is tricky with DesignSpark because it requires that every component have a unique reference designator. One method is to give each board a unique suffix to the designators when renaming them. For example R1 could be R1A, R1B, R1C and R1D. DesignSpark will now be able to quote the panelized board, but you will still need to contract the PCB manufacturer to make sure that they are able to accept panelized boards.

Conclusion

Today we modified our design so that DesignSpark could give us BOM and PCB cost estimates. Next time we’ll look at how DesignSpark can render a 3D image of the board.

(130247)

Arduino

Now Available @ Elektor!

10% OFF for
GREEN and
GOLD Members

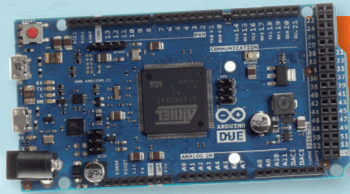

ARDUINO DUE

32-bit power thanks to an ARM processor

Features	
Microcontroller	AT91SAM3X8E
Operating Voltage	3.3V
Input Voltage (recommended)	7-12V
Input Voltage (limits)	6-20V
Digital I/O Pins	54 (of which 12 provide PWM output)
PWM Channels	12
Analog Input Pins	12
Analog Outputs Pins	2 (DAC)
DC Current per I/O Pin	130 mA
DC Current for 3.3V Pin	800 mA
DC Current for 5V Pin	800 mA
Flash Memory	512 KB (all available for the user applications)
SRAM	96 KB (two banks: 64KB and 32KB)
Clock Speed	84 MHz

£47.00 • € 52.77 • US \$76.50



ARDUINO MEGA

Like the Uno but with more memory and I/O

Features	
Microcontroller	ATmega2560
Operating Voltage	5V
Input Voltage (recommended)	7-12V
Input Voltage (limits)	6-20V
Digital I/O Pins	54 (of which 15 provide PWM output)
Analog Input Pins	16
DC Current per I/O Pin	40 mA
DC Current for 3.3V Pin	50 mA
Flash Memory	256 KB (of which 8 KB used by bootloader)
SRAM	8 KB
EEPROM	4 KB
Clock Speed	16 MHz

£47.00 • € 52.77 • US \$76.50

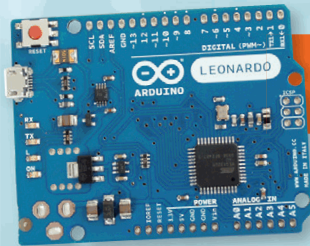

ARDUINO LEONARDO

Especially good for USB applications

Features	
Microcontroller	ATmega32u4
Operating Voltage	5V
Input Voltage (recommended)	7-12V
Input Voltage (limits)	6-20V
Digital I/O Pins	20 (of which 7 provide PWM output)
PWM Channels	7
Analog Input Pins	12
DC Current per I/O Pin	40 mA
DC Current for 3.3V Pin	50 mA
Flash Memory	32 KB (of which 4 KB used by bootloader)
SRAM	2.5 KB
EEPROM	1 KB
Clock Speed	16 MHz

£22.10 • € 24.81 • US \$36.00

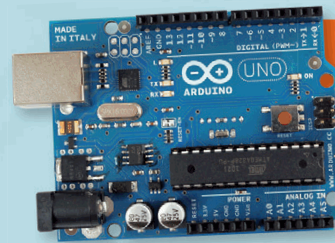

ARDUINO UNO

The most popular board with its ATmega328 MCU

Features	
Microcontroller	ATmega328
Operating Voltage	5V
Input Voltage (recommended)	7-12V
Input Voltage (limits)	6-20V
Digital I/O Pins	14 (of which 6 provide PWM output)
PWM Channels	6
Analog Input Pins	6
DC Current per I/O Pin	40 mA
DC Current for 3.3V Pin	50 mA
Flash Memory	32 KB (of which 0.5 KB used by bootloader)
SRAM	2 KB
EEPROM	1 KB
Clock Speed	16 MHz

£24.40 • € 27.35 • US \$39.70

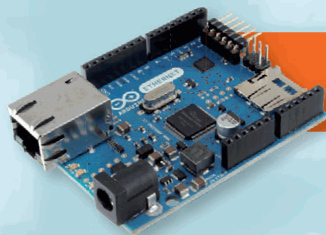

ARDUINO ETHERNET

Networking has never been easier

Features	
Microcontroller	ATmega328
Operating Voltage	5V
Input Voltage (recommended)	7-12V
Input Voltage (limits)	6-20V
Digital I/O Pins	14 (of which 4 provide PWM output)
Arduino Pins reserved	10 to 13 used for SPI 4 used for SD card 2 W5100 interrupt (when bridged)
Analog Input Pins	6
DC Current per I/O Pin	40 mA
DC Current for 3.3V Pin	50 mA
Flash Memory	32 KB (of which 0.5 KB used by bootloader)
SRAM	2 KB
EEPROM	1 KB
Clock Speed	16 MHz

£48.10 • € 53.98 • US \$78.30



ARDUINO YÚN

Two processors

Features AVR microcontroller	
Microcontroller	ATmega32u4
Operating Voltage	5V
Input Voltage	5V
Digital I/O Pins	20
PWM Channels	7
Analog Input Channels	12
DC Current per I/O Pin	40 mA
DC Current for 3.3V Pin	50 mA
Flash Memory	32 KB (of which 4 KB used by bootloader)
SRAM	2.5 KB
EEPROM	1 KB
Clock Speed	16 MHz

Features Linux microprocessor	
Processor	Atheros AR9331
Architecture	MIPS @400 MHz
Operating Voltage	3.3V
Ethernet	IEEE 802.3 10/100Mbit/s
WiFi	IEEE 802.11b/g/n
USB Type-A	2.0 Host/Device
Card Reader	Micro-SD only
RAM	64 MB DDR2
Flash Memory	16 MB
PoE compatible 802.3af card support	

£62.30 • € 69.95 • US \$101.40



Further Information and Ordering at www.elektor.com/arduino

CHRISTMAS SHOPPING @ ELEKTOR

20
Products
to choose
from

Discounts
up to
58%

3 Products
for just
£45.00*

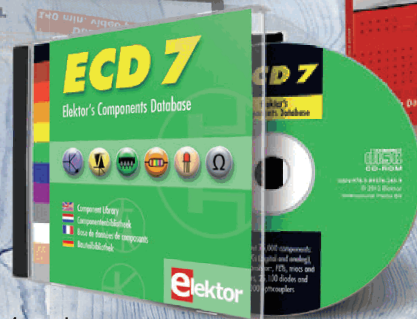
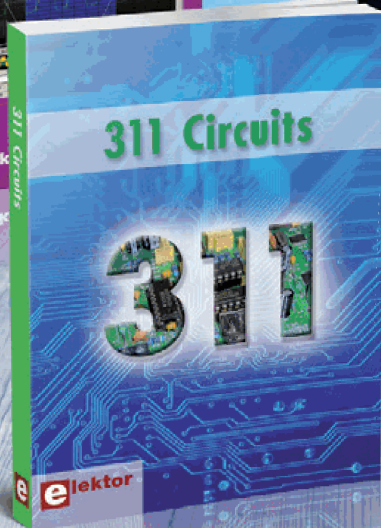
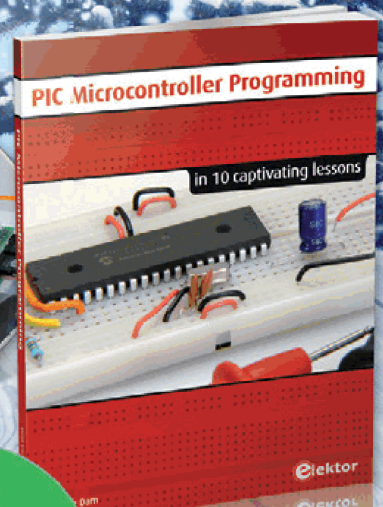
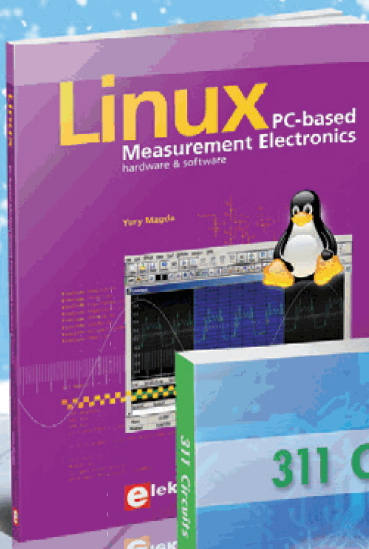

* Approx. €53 / \$72. Offer valid until 1 January 2014 and as long as stocks last. Excl. Shipping & Handling.

Make Your Choice Today at www.elektor.com/christmasoffer

Surfin' the RPi Wave



By Clemens Valens
(Elektor.Labs)

Raspberry Pi (RPi) may very well enter electronics history as the board that changed the game. The RPi team has shown that it is possible for “normal” engineers to develop systems that can compete with products marketed by big companies with tons of resources. Due to the RPi’s attractive pricing and its impressive capabilities over a million pieces were sold in a year. It’s no wonder quite few RPi based projects appear on the Elektor.Labs website.

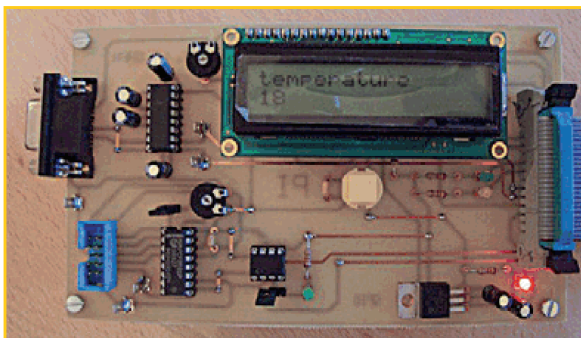

Getting Started

OP **ale**, well known to regular Elektor readers from his excellent Sounding Balloon project published in Elektor.Post #17 (see below), came up with an add-on card for the RPi. But, since this OP is into teaching, he also wrote three detailed RPi How-To articles. Albeit they’re written in French, the articles are full of annotated screenshots and photographs, making them accessible to an extent to all of us. And if you really don’t understand what the OP is talking about, contact him through the project’s webpage. He (or possibly someone else) will be glad to help you out.

www.elektor-labs.com/node/3084

Never Lose Data Again

As Murphy’s Law says, there are two types of computer users: those who have lost data and those who are about to lose data. To prevent a second event of this type, OP **Antoni** has built a Network Attached Storage (NAS) composed of a 2-Terabyte USB hard disk and a Raspberry Pi, which connects the hard disk to the OP’s home network via Ethernet. A USB hard disk is much cheaper than an Ethernet version, so this is an economical solution to your data storage worries. The OP provides detailed instructions on configuring and setting up the system. Now you no longer have an excuse for not backing up your important data.

www.elektor-labs.com/node/2892

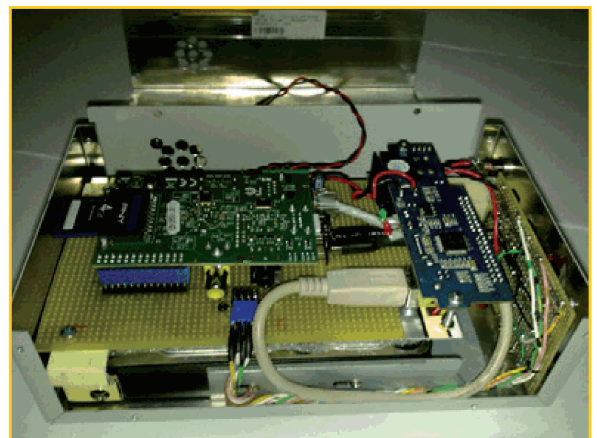

Prototyping Board

This RPi prototype board provides a beefier 3.3 V DC power supply than the RPi's on-board regulator. Now you have up to 800 mA available for your experiments. Furthermore, the prototyping board provides an easy means to access the signals from the RPi expansion connector. A special connector breaks out the RPi signals, allowing you to use them easily in your circuits. This project was published in the March 2013 edition of Elektor and the PCB is available through the Elektor Store. www.elektor-labs.com/node/2703

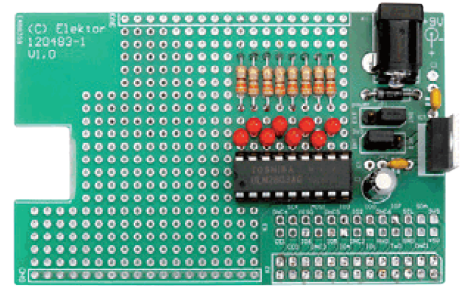

www.elektor-labs.com

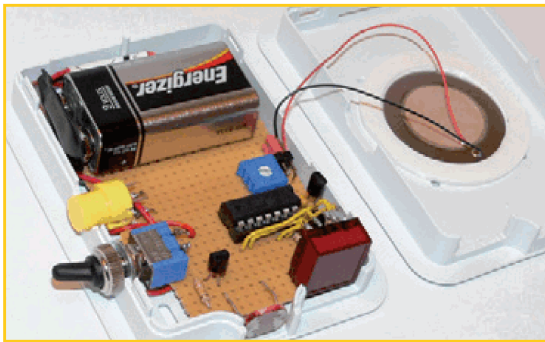

Refrigerator Watchdog

Soon after the apparition of the RPi, enclosure companies started to produce RPi enclosures, especially for those people who only wanted to use their RPi as a Media Center. These enclosures are rather cheap and some even look nice. This triggered OP **joergt** to use them for his 8-bit AVR projects too. This example shows how to create a nice-looking fridge surveillance system on a shoestring using an RPi enclosure. Now that's what I call out-of-the-box thinking!

www.elektor-labs.com/node/3596

Five Cool Projects

Universal Display Extension

www.elektor-labs.com/node/3602

LP Gas Fuel Injection for Single Cylinder Engines

www.elektor-labs.com/node/3585

MOS6581-based Chiptunes Player

www.elektor-labs.com/node/3575

Embedded Chip-8 Video Game System

www.elektor-labs.com/node/3555

Using Your Hand as a Mouse

www.elektor-labs.com/node/3489



elektor post

There's More in .POST

If you are into or interested in Raspberry Pi projects and if you are an Elektor Member, you have access to six additional RPi articles. These articles were sent to every Member who also receives our weekly newsletter Elektor.Post. If you have missed these articles, you can still read them as they are archived on the Elektor.Magazine website. As an Elektor Member you have access to this website from where you can download these articles (and many more). Your login credentials for Elektor.Magazine are the same as for Elektor.Labs.

Did you know that over the last months some twenty extra projects have been sent to our members through our newsletter called Elektor.POST? You did not receive them or you accidentally deleted one? No sweat, they're all available on our website. Sign up for Elektor.POST at www.elektor.com and never miss a free project again.

Get previously published .POST articles here: www.elektor-magazine.com/com/extra/post.html

Note: OP stands for Original Poster—the person who started an online project or discussion. OPs wishing to qualify for their project being published in Elektor magazine (i.e. on paper) must regularly check the email address they use to access Elektor.Labs. This is our only means of contact.

Atmel: New ARM Cortex-M0+ Microcontroller Family



Atmel Corporation announced the new Atmel® SAM D20, the first series in a new family of embedded Flash microcontrollers based on the ARM® Cortex™-M0+ processor core and designed ideally for home automation, consumer, smart metering and industrial applications. Leveraging two decades of microcontroller experience and success with the company's easy-to-use AVR- and ARM-based products, the new series combines innovative and proven technologies including intelligent peripherals with Atmel's Event System and capacitive touch support for button, slider and wheel capability and proximity sensing. The new SAM D20 series is also supported by the latest version of Atmel Studio and Atmel Software Framework, the integrated development platform for developing and debugging Atmel ARM Cortex-M and Atmel AVR® MCU- based applications.

Bosch Sensortec GmbH is among the first adopters of the new Atmel SAM D20 device.

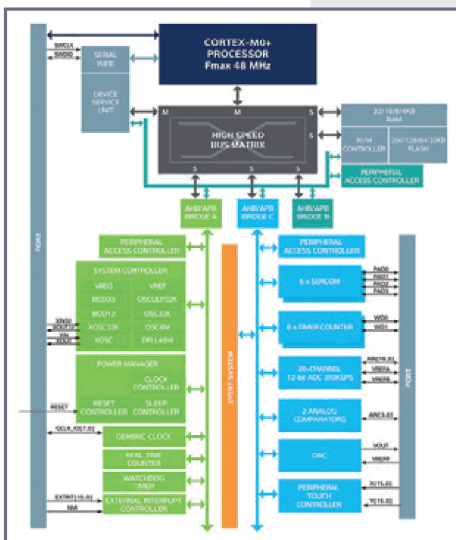

Atmel's SAM D20 Cortex-M0+ ARM-based series integrates several popular features including high-precision 12-bit analog and internal oscillators, up to eight 16-bit timer/counters, real-time performance, peripheral event system, and flexible clocking options and sleep modes. The new devices also include a serial communication module (SERCOM module) that can be configured from the application to act as an USART, UART, SPI and I²C; each device in this new family includes four to six SERCOM modules. The new devices are also designed for a simple and intuitive migration between devices with identical peripheral modules, hex compatible code, pin compatible migration paths, and a linear address map.

The family supports button, slider and wheel touch capability as well as proximity without the need for external components, and features 14 new devices available in 32-, 48- and 64-pin package options with 16 to 256 KB of Flash memory.

To accelerate design, the SAM D20 Xplained PRO evaluation kits are available today for USD \$39. The kit features a 64-pin, 256 KB SAM D20 device along with a programmer/debugger and hardware to evaluate both the processor and the peripherals. The Xplained PRO kit also comes pre-loaded with software that can easily be re-programmed, debugged and prototyped without any additional tools.

www.atmel.com (130202-VI)

Varta MicroBattery: Power Pack Solutions



Successfully designing high-end power packs for the Industrial, Medical and Communications markets, VARTA Microbattery now expands with the BIKE division to bring their know-how into pedelecs and e-bikes.

The service offers a package from design-in to testing, the complete range of steps from A to Z which are indispensable to offer a strong, safe and aesthetically pleasing Power Pack for pedelecs.

One design example is the new off-the-shelf product which provides a continuous discharge current of 25 A and a peak current of 30 A. Common pedelec power packs provide just continuous discharge currents of 14 A to 15 A and peak currents of 20 A. Thanks to this high discharge rate the VARTA Microbattery battery can run the motor longer at its maximum power of 250 W than other systems can.

www.varta-microbattery.com/cellpacbike (130202-VIII)

Wireless Battery-Free Sensor Systems

Farsens (Spain) has developed wireless sensor devices that can be used without the need of batteries on the sensors. These battery free sensor tags are based on UHF RFID technology and are able to continuously monitor and transmit data, together with the 96-bit EPC unique tag identifier, to any EPC Gen 2 standard compliant reader. Farsens has packed everything you need to have a full passive sensor system up and running with no effort. Their Full Battery-Free Sensor kits come with their wireless battery free sensor tags of choice plus a commercial UHF RFID reader, a reader antenna, reader power supply and Ethernet cable to connect to your PC or laptop. The kit also comes with a software program that displays the sensor tag data on your computer. Tags in these kits come in non-protected PCB formats for custom encapsulation or embedding in non-metallic assets/materials. There are four sensor options for the Basic and Regular choices:

- Battery Free Temperature Sensor (BFTS)—any kit focused on temperature monitoring includes FENIX wireless battery-less temperature sensor tags.
- Battery Free Pressure Sensor (BFPS)—pressure

monitoring kits include VORTEX wireless battery-less pressure sensor tags.

- Battery Free Orientation Sensor (BFOS)—when the users need a kit to monitor spatial orientation of assets KINEO wireless battery free sensor tags are shipped.
- Battery Free Switch Sensor (BFSS)—any kit desired to monitor the open/close status of a mechanical switch is shipped with X1 wireless battery free switches.

Farsens designs and manufactures full passive RFID sensor solutions. Their proprietary UHF RFID IC allows Farsens to develop long range solutions for asset tracking—via the unique ID—and monitoring—via the attached sensor—without the need of any battery on the tag.

(130202-VII)

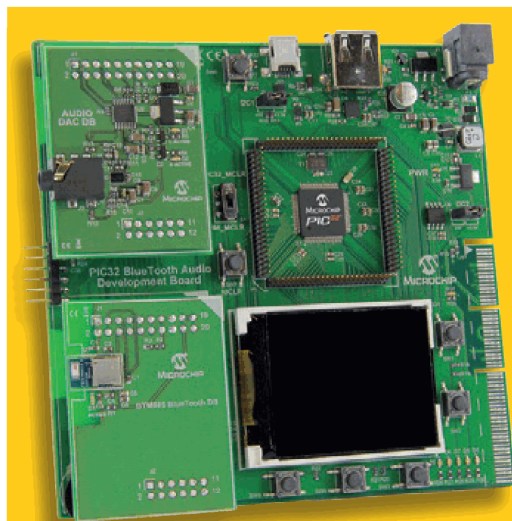

PIC32 Bluetooth® Audio Development Kit

Microchip announced a new PIC32 Bluetooth® Audio Development Kit. The full-featured kit enables custom application development on the PIC32 microcontrollers (MCUs) for Bluetooth and USB digital audio solutions.

The creation of the Advanced Audio Distribution Profile (A2DP) by the Bluetooth Special Interest Group (SIG) has enabled convenient wireless stereo audio for applications such as smartphone home and automotive audio docks, wireless speakers, A/V receivers and all-in-one compact audio systems among others. Bluetooth audio support is now a regularly seen requirement for smartphone docking solutions. Consumers are able to use their phone as a music source, as well as, a remote control to select the song of their choice and play it from across the room.

The PIC32 Bluetooth Audio Development Kit that ships with audio streaming demo code delivers up to 24-bit, 192 kHz audio and has been tested with over 100 different Bluetooth audio enabled devices, spanning 18 different manufacturers. The Bluetooth Hardware module and the Bluetooth A2DP audio software have been Bluetooth.org certified, saving

the developer significant certification costs. The modular design allows developers to swap out the included daughter boards (one for Audio and one for Bluetooth), to create their own custom versions with their preferred audio and wireless solution. The kit also supports USB Host and Device connectivity, Apple® device authentication module interface, a 2-inch color LCD, five general-purpose button switches, 5 LEDs and a Plug-In-Module interface for PIC32 microcontroller upgrades.

The PIC32MX450F256 MCU is included which runs at 80 MHz with 256 KB Flash and 64 KB RAM. With such a broad feature-set and flexibility, the kit makes an excellent general purpose development tool.

The PIC32 Bluetooth Audio Development Kit (part # DV320032, \$199.99), Bluetooth Audio Suite 1 (part# SW320014-1, \$299.00), Bluetooth Audio Suite 2 (part# SW320014-2, \$499.00) are available for purchase today.

www.microchip.com/get/1FL9 (130249-I)

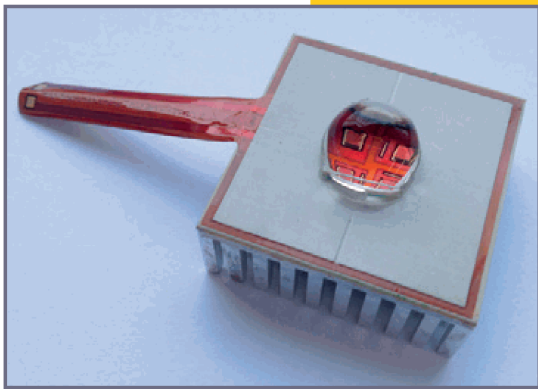

NANOTHERM™ Dramatically Improves Chip-on-Heat-Sink Technology

UK firm Cambridge Nanotherm has won a Frost & Sullivan Innovation Award for Chip-on-Heat-Sink designs enabled by NANOTHERM™, a substrate technology that combines ultra-low thermal resistance with high dielectric strength.

Manufacturers of electronic devices that run hot, such as power supplies, power LEDs and thermoelectric circuits, can achieve excellent thermal performance and electrical isolation by using NANOTHERM, at a substantially lower cost than comparable aluminum nitride-based substrates in use today.

By reducing the cost of producing a strong dielectric (75 kV/mm) with ultra-low thermal resistance (0.02°Ccm²/W), Cambridge Nanotherm has thus brought high thermal performance within reach of a much wider range of applications.

NANOTHERM draws on a patented technique for growing a dielectric ceramic layer of nano-scale aluminum oxide crystals on aluminum of any shape. It enables precise control of the ceramic layer's thickness to sub-micron tolerances, to produce substrates with precisely specified dielectric strength and thermal resistance.

In the Chip-on-Heat-Sink (CoHS) implementation cited by Frost & Sullivan, a NANOTHERM dielectric layer grown on a heat sink is combined with metallization, which bonds a copper circuit layer to the dielectric. This allows a chip to be mounted directly on a heat sink, eliminating the PCB and adhesive layers which are required in conventional assemblies, and which constrict the flow of heat from the chip to the heat sink.

Frost & Sullivan has recognized the value of this technology to manufacturers of LED lighting equipment, awarding Cambridge Nanotherm its *2013 European Thermal Management Solutions for LED Lighting Technology Innovation Award*.

NANOTHERM technology allows the temperature at which the LED die runs to be lowered by up to 22°C. As such, higher power can be pushed to the LED, thus increasing its light output. This in turn means customers can operate fewer LEDs but get higher light output at the same time.

Steven Curtis, Chief Engineering Officer at Cambridge Nanotherm, said: "This Frost & Sullivan innovation award is a testament to the huge impact NANOTHERM is set to make across of a wide range of high-temperature electronics applications. Until now, the very high thermal performance of advanced dielectric materials has only been matched by their very high price. The innovative mass-production techniques underpinning our NANOTHERM technology mean that a dielectric offering negligible thermal resistance is now available to every mainstream and cost-sensitive application."

Products based on NANOTHERM technology are available now in production volumes. These include isolated heat sinks, CoHS implementations, substrates for hybrid circuits, and lightweight replacements for direct-bonded copper substrate.

www.camnano.com. (130249-VI)

Audio Precision Brings AP Performance to Loudspeaker Test

Audio Precision announced a new software release that expands the features of the electro-acoustic test suite for APx audio analyzers. APx v3.4 adds Thiele/Small parameters, Complex Impedance and Loudspeaker Production Test to the APx platform. This expanded electro-acoustic capability makes APx audio analyzers the preferred choice for designing and testing integrated audio products that incorporate electronics, digital signal processing and loudspeakers. In addition to the new measurements, the APx electro-acoustic suite includes an Energy Time Curve (for quasi-anechoic measurements), Impulse Response, Frequency Response, Rela-

tive Level, Phase, Distortion Product Ratio, Distortion Product Level, Rub and Buzz, and Modulated Noise (for air leak detection). Output options include waterfall charts and polar plots via APx utilities. Converged Audio Test covers all aspects of today's integrated audio products. AP is the recognized standard in analog audio test with ultra-low distortion, wide input and output ranges and high accuracy measurements, while APx I/O options provide native connectivity for a wide range of digital formats including Bluetooth, HDMI, PDM, and Digital Serial. With the expansion of the APx electro-acoustic test suite, integrated audio products can be tested in

every domain, at every step from R&D to Production. R&D engineers working on integrated audio products must be able to obtain reliable results from each part of the signal chain, from analog inputs to digitally processed compensation to power amplifiers and loudspeakers. The complete APx electro-acoustic suite is ideal for these tasks, with incredible flexibility and reporting capacity. The full range of Thiele/Small parameters may be obtained using added mass, known volume or known mass methods.

For high speed production test, impedance magnitude and phase plus a limited set of Thiele-Small parameters are calculated (along with Frequency Response, Relative Level, Phase, Distortion Product Ratio, Distortion Product Level, Rub and Buzz) from a single log sweep. Because APx is a unified platform, R&D can define tests and acceptable ranges of results, sending this information directly to the factory for complete quality control of the manufacturing process.

The new electro-acoustic measurements are enabled through two new software options. Both options are available concurrent with the APx500 v3.4 release. An APx analyzer is required to run the measurements. All models support the below options.

APX-SW-SPK-RD (for R&D): Impedance magnitude, Impedance phase, Impedance real, Impedance imaginary, complete Thiele-Small Parameters, Energy Time Curve, Impulse Response, Frequency Response, Relative Level, Phase, Distortion Product Ratio, Distortion Product Level, Rub and Buzz, and Modulated Noise.



Includes all measurements in the Loudspeaker Production test measurement detailed below and polar plots and waterfall graph utilities. Price is \$1500 in US.

APX-SW-SPK-PT (for production test): Frequency response, Relative Level, Phase, Distortion Product Ratio,



Distortion Product Level, Rub and Buzz, Impedance Magnitude, Impedance Phase, Limited Thiele-Small Parameters and Modulated Noise. Price is \$750 in US.

<http://ap.com> (130249-II)

PCB Pixture: Personalized PCBs

Why would you want to personalize the appearance of your PCB design? Well, your boards may be visible in the final product and you want to add customer appeal or brand awareness. Or as a prototype designer you want your customers and prospects to recognize your work and send you new projects. Existing ways to personalize PCBs include adding a logo in the legend; using a different solder mask color or designing a recognizable board shape. Now Eurocircuits offers something more—PCB PIXture.

Eurocircuits developed software to break a graphical image into pixels and convert the image to DPF (dynamic process format) or extended Gerber. These are formats used in PCB production. With this software tool, graphical layers as well as other PCB design layers can be combined. Eurocircuits can now add any graphical image into a PCB dataset and create an extra image layer for printing as a solder mask layer. The PCB PIXture is printed on the boards as a double solder mask layer. The first layer is a white photo imageable solder mask made in the normal way. The second layer, printed over the first, is a black solder mask layer with the artwork based on the PIXture file. This process does not affect the functionality of the board or the solderability, as the material used is standard photo imageable solder mask ink. PCB Pixture is now available on request and will be implemented soon in Eurocircuits PCB pooling services.

<http://www.eurocircuits.com/index.php/eurocircuits-printed-circuits-blog> (130249-V)

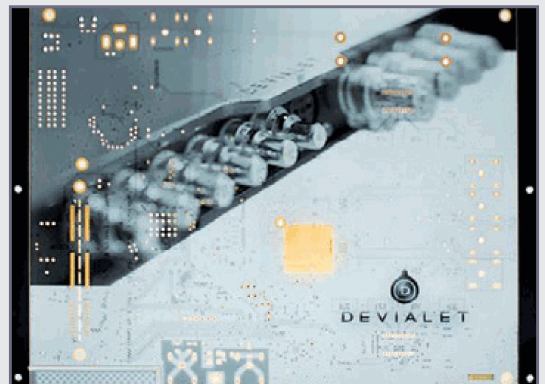

Microgrids

Independent local power grids

By
Tessel Renzenbrink
(Elektor TTF Editor)

The residents of the Faroe Islands have set up their own microgrid. A microgrid is an autonomous local network of distributed power sources and loads. It can operate either independently (“island mode”) or linked to the main power grid. When linked to the main power grid, it can supply or receive power. An important property of a microgrid is that it acts as a single controllable unit with respect to the main power grid. Microgrids are one of the answers to the question of how to increase the share of sustainable sources in the energy mix.

At the Microgrid Forum held in Amsterdam on September 18 and 19, Bjarti Thomsen, an engineer and project developer at the Faroese Earth and Energy Directorate, explained why they opted for a microgrid.



The Faroe Islands are situated in the North Atlantic Ocean approximately halfway between Norway and Iceland. They form an autonomous administrative district within the Kingdom of Denmark. Due to their isolated location, the Faroe Islands have never been connected to the mainland power grid. Their main source of energy is imported oil.

Staying warm, particularly in the winter, is an expensive proposition. The average household consumes about 1,000 gallons of oil per year at a cost of 24,000 Danish crowns (about \$4,300; €3300; £2700).

The island residents, numbering roughly 50,000, decided to make the move from fossil fuels to sustainable energy. They have various reasons for this, including the anticipated economic pressure from rising oil prices, greater independence in meeting their energy needs, and reducing CO₂ emissions.

The climate and the location of the Faroe Islands offer good prospects for utilizing alternative energy resources. There’s nothing to stop the wind in the middle of the ocean, and particularly in the winter months—when energy demand is

greatest—there is a lot of wind. A microgrid has been established on Nólsoy, one of the eighteen Faroe Islands, to add wind to the energy mix.

Sustainable power integration

The power grid of the Faroe Islands, like most national grids, is not designed to accommodate the large-scale integration of distributed intermittent power sources. It is a centralized grid with a limited number of large power plants. The distribution network only works in one direction: from the power plants to the loads. The network manager can control the supply, but not the demand. Connecting a large number of sources supplying power on an irregular basis to a grid of this sort causes variations in the grid voltage.

By contrast, a microgrid can accommodate fluctuations in generation because it uses computer systems to manage the power balance intelligently and dynamically. Demand and supply are coordinated by shedding loads when less generating capacity is available. Based on a priority scheme, the supply of power to specific devices, such as those having their own batteries (electric cars and laptop computers, for example), is temporarily discontinued.

Another important component of a microgrid is energy storage. This acts as a buffer to handle periods when generating capacity is greater or less than demand. Energy can be stored in batteries or other facilities when the grid voltage rises, and then fed back into the grid when the voltage drops.

Dynamic network management enables a microgrid to handle a large number of distributed

sources, such as wind turbines and solar panels. It uses them primarily to supply power to the loads in its own network. If excess capacity is available, it supplies power to the main grid as a single entity. In this way it acts as an intermediary between distributed energy sources and the main grid.

Obstacles

Microgrids do not come cheap. At present the cost per kilowatt-hour is not competitive with conventional power grids. This is why microgrids are mainly implemented in isolated locations such as islands, mining sites and isolated rural communities. Most of the people attending the forum in Amsterdam were stakeholders: investors, companies, engineers and representatives of areas where microgrids are potential option. Accordingly, a lot of attention was also given to the obstacles to cost-effective operation.

Microgrids do not scale easily. Each location is unique in terms of energy demand and available energy resources. In the case of the Faroe Islands system, the main requirement is to meet the demand for heat, and wind energy is available. By contrast, a microgrid for a mining site in the outback of Australia has to be able to keep heavy machinery running using diesel generators, solar panels and wind energy. It is therefore not possible to build an optimized microgrid that can be exported to every corner of the world.

A related aspect is the lack of standardization. Microgrids rely on complex interactions between generators, storage facilities, voltage and frequency control systems and computer infrastructure. From many of the stories related by various speakers at the forum, it was apparent that each time a microgrid is developed and implemented, the parties involved in the process have to devise new solutions in order to achieve interoperability between the various systems. The forum attendees agreed that better coordination between the players in the chain would foster the development of microgrids.

It was also clear that energy storage is still a bottleneck for the large-scale implementation of intermittent energy resources. Enormous advances in battery technology with regard to quality and cost have been made as a result of the automobile industry's massive interest



in electric vehicles. However, the cost per kilowatt-hour of energy from sustainable resources in combination with battery storage is still significantly higher than with a conventional power grid. It can be cost-effective for isolated areas without access to a power grid, such as the Faroe Islands, but for ordinary use battery storage is still too expensive.

A member of the audience raised the question of why the discussion on energy storage focuses almost entirely on batteries instead of considering other options, such as hydrogen or flywheels. No truly satisfactory answer was given.

Nevertheless, there is a genuine future for microgrids. The share of renewable energy in the mix will continue to grow due to the finite nature of fossil fuels and the resulting rise in fuel prices, as well as efforts to reduce CO₂ emissions. Popular support for alternative forms of energy can also be seen from the fact that more and more people want to look after their own energy needs. At the household level this can be achieved by installing solar panels on the roof, but it can also be achieved at a larger scale by joining together to launch a wind turbine project.

To enable the utilization of distributed intermittent resources, current centralized power grids will have to be transformed into smart, dynamic 21st-century systems. Microgrids offer a means to implement this transition in a phased manner.

(130250-I)

Internet Link

[1] www.microgridforum.com/

The next edition of the Microgrid Forum will be held on November 11-13 in Singapore.

Bendix 60B4-1-A AC/DC Insulation Tester

Megger, Hi-Pot, and Arc-in-the-Dark

By **Chuck Hansen**
(USA)

The theory behind insulation and dielectric testing is that if the insulation system in the equipment under test can withstand a deliberate overvoltage stress, it will easily operate under all specified normal and abnormal electrical and environmental conditions for its entire design life.

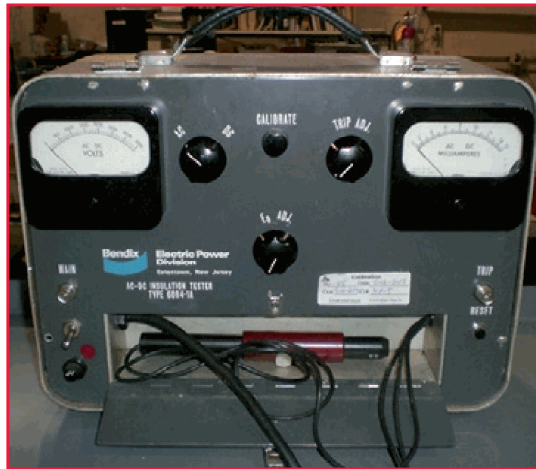

Figure 1.
60B4 Insulation Tester front
panel.

The original insulation test method used a high voltage AC power supply with an external milliammeter to read the leakage current. Back in the late 1950's Bendix decided to design a more versatile AC-DC high-voltage insulation tester. It was assigned Bendix type number 60B4-1-A. While it was initially designed for in-house production testing, a market evolved among their customers since the 60B4 was quite robust and fool-proof. 60B4 testers even show up occasionally on eBay.

The tester came with an aluminum carrying case and a latching removable front cover. It is roughly 16 x 10 x 8 inches (415 x 260 x 200 mm). With its three large power transformers and a variac, it weighed a hefty 28.5 lbs (13 kg). The three-wire power cord and three test probes are stored in a compartment at the bottom-front of the tester, and are an integral part of the tester. This is done to prevent loss of the expensive probes or

substitution of unsafe probes (alligator clips, etc.) with inadequate insulation (**Figure 1**).

The 60B4 has an output voltage range of 0 to 3500 volts AC or DC, with an adjustable trip level from 2 to 15 mA. Testing could be monitored by means of the 0-3500 voltmeter and 0-15 mA meter on the front panel.

The tester has three test probes constructed from Bakelite tubes. The black probe is common, while the red probe (above) is for DC testing and the yellow probe is for AC testing. The high-voltage brass probe tips are spring-loaded and automatically retracted inside the Bakelite handle when the operator released the extension slide button (the white button on the probe above).

The rotary switch next to the front panel voltmeter selects AC or DC test mode. The TRIP ADJ control next to the milliammeter is used to adjust the mA trip level, which trips a relay to cut off the applied voltage if the test current exceeded the trip level. This trip current is set in either AC or DC mode with the following procedure:

1. Set the test voltage to zero with the EO ADJ variac control.
2. If the TRIP light is illuminated, press the RESET switch on the right, below the AC DC MILLIAMMETER.
3. Turn the TRIP ADJ control fully clockwise.
4. Press, then hold in, the CALIBRATE pushbutton switch.
5. Slowly increasing the EO ADJ variac until the desired value of trip current is shown on the AC DC MILLIAMPERE meter.
6. With the CALIBRATE switch still depressed, turn the TRIP ADJ control slowly counter-clockwise until the TRIP lamp illuminates.

Aerospace and military test requirements

The MIL specs to which aerospace electric power equipment is designed calls for the following insulation and high-potential (Hi-Pot) dielectric test methods:

1. There is an initial insulation resistance test with a hand-cranked permanent magnet generator that produces 500 VDC. This device, also called a Megger, has a very high megohm resistance scale. The insulation resistance must read above a specified megohm value.
2. Next, a Dielectric Strength (Hi-Pot) Test at commercial power line frequency is applied between the machine current-carrying conductors and metal frame for the specified time. Electronic Control units are tested from each connector terminal to case.
3. RFI filter capacitors and electronic devices shall be disconnected if this test is likely to damage them. Electronic units required use of a special shorting connector which connects all active connector pins together, with a separate pigtail wire which is connected to the metal chassis. Test condition A pertains through qualification and field usage, and the higher-stress condition B is required during acceptance testing.
 - a. Circuits of 50 V and less; 500 V_{rms} for 1 minute or 600 V_{rms} for 5 seconds.
 - b. Circuits over 50 V; Twice rated voltage plus 1,000 V_{rms} for 1 minute, or 120 percent of the 1 minute voltage for 1 second.
 - c. Capacitors and electronic devices prior to assembly shall be subjected to and shall withstand a dc test voltage of twice the maximum peak voltage encountered during normal operating conditions.
4. Equipment designed for 28 VDC aircraft power (a) is Hi-Pot tested at 500 V_{rms} (Test condition A) or 600 V_{rms} (Test condition B).
5. Equipment designed for 115 VAC three-phase aircraft power (b) is Hi-Pot tested at 1250 V_{rms} (test condition A) or 1500 V_{rms} (test condition B). This particular AC test level is used because a 115 VAC power source, generator or inverter, has to compensate the feeder voltage drop between the source output terminals and the 115 VAC point-of-regulation at the power contactor input terminals. With all the

ESTD 2004

Retronics is a monthly section covering vintage electronics including legendary Elektor designs. Contributions, suggestions and requests are welcome; please telegraph editor@elektor.com

tolerances on rated voltage and up to 5 V_{rms} feeder drop, this could result in a steady-state 125 V_{rms} at the source output terminals, thus the 1250 or 1500 V_{rms} test level.

You can see how this procedure could require a three- or four-handed operation, since it required holding two test probes against the unit under test (UUT), then slowly adjusting E_o to the specified test voltage while also monitoring the leakage current. This inevitably led to many resourceful, but unauthorized, methods to defeat the auto-retract safety feature of the test probes using alligator clip leads to connect at least one probe to the UUT.

When AC voltage is used for the Hi-Pot test, there will always be some leakage current because of the capacitance from windings or circuitry to the metal frame or chassis. The operator slowly increases the test voltage up to the specified limit. There is always the chance for any insulation breakdown to be potentially damaging (pun intended). The 60B4, with its mA Trip protection is designed to prevent extensive insulation damage in case of an arc-over. An electrical arc might leave a carbon track or even break through the insulating material. The operator then has the chore of finding the exact the arc fault location, which requires darkening the work area in order to see the arc during a retest.

Bendix furnished large black cloths at the test stands. The worker had to cover himself and the unit under test along with the Hi-Pot probes, then repeat the Hi-Pot test until he managed to notice the brief arc flash that pointed the way to the insulation failure location. In the summer, it was quite warm under the black cloth because Bendix had not yet air conditioned the production areas. Later 60B4 units had a motorized E_o variac with an automatic voltage rise-time control circuit similar to that in a triac light dimmer. E_o is the output voltage (AC or DC) at the M1 voltmeter.

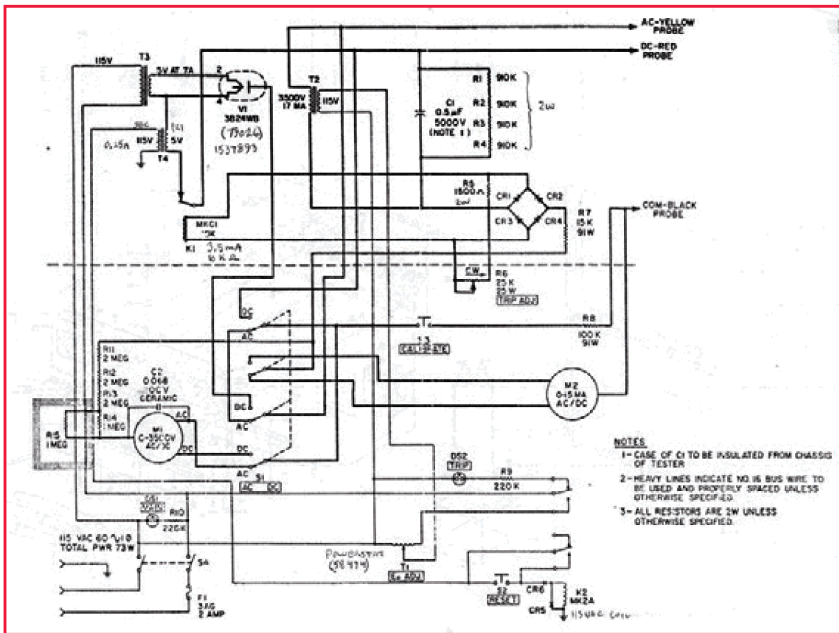

Figure 2. 60B4-1-A schematic diagram.

After the operator pre-set the maximum Eo uvt voltage, he used a foot-pedal switch to start and stop the Eo test. That made it easier to concentrate on finding the insulation failure. Assuming the equipment passes the Megger and Hi-Pot test, it then had to pass a follow-up Megger test to ensure there is no latent insulation damage from the Hi-Pot test.

60B4 Circuitry

Figure 2 shows the schematic for the 60B4. When power switch S4 is closed, AC line power is connected to the primary of transformer T3, which supplies 5 VAC filament power to vacuum tube V1. V1 is a 3B24WB half-wave rectifier rated for 20 kV PIV and 60 mA average DC current. It supplies high-voltage DC for the DC test mode.

The tube in the unit featured in this Retronics installment was manufactured by Cetron. The secondary of T3 is also connected to the secondary of another 5 V transformer, T4. The 115 VAC primary winding of reverse-connected T4 is applied through the normally-closed (NC) contact of K1 to the coil of relay K2 when momentary RESET Switch S2 is pressed. The coil circuit is sealed in by one of the normally-open (NO) contacts of K2 so S2 can be released. The second K2 contact set applies power to the TRIP indicator DS2 when tripped, and to Variac T1 when K2 is closed. Note that the low side of Relay K2 coil is connected to the 60B4 chassis rather than to the AC line neutral.

In AC test mode variac T1 provides variable AC line voltage to the primary of high voltage transformer T2, rated for 3500 VAC at 17 mA. The high side secondary of T2 is connected directly to the yellow AC test probe. The low side of T2 is in series with the AC connections of a full-wave diode bridge consisting of CR1-CR4, R7 and the wiper of one contact set of AC-DC mode switch S1. S1 connects R7 to the AC input stud of milliammeter M2. The common lug of M2 is connected to the black Common test probe, completing the circuit from the AC test probe through the dielectric/insulation material being tested. Voltmeter M1 shows the test voltage level. The CR1-CR4 rectifier bridge DC output is loaded by the coil of K1, which serves as the test current sensing circuit. The bridge is also shunt loaded by R5 and TRIP ADJ control R6. When the control is fully CW to its minimum resistance, most of the bridge current flows through R5. As the TRIP ADJ control is adjusted CCW to increase its resistance, more current flows through the coil of trip relay K1. Once the trip current level is reached, K1 will operate and open the 5 VAC winding of T4. This removes the 115 VAC from the coil of K2. K2 will trip and open the AC line connection to variac T1, and illuminate the TRIP indicator.

When CALIBRATE switch S3 is depressed, it completes a circuit to the black Common probe through dummy load resistor R8. R8 is 100 kohms, 91 watts (!) and draws 1 mA for each 100 volts AC or DC of test voltage. In DC test mode the high-voltage winding of T2 is switched by S1 to the plate cap of V1. The half-wave rectified high-voltage at the filament/cathode is filtered by C1 into a smooth DC level

About Bendix

Bendix Red Bank Division (later the Bendix Electric Power Division) in Eatontown, NJ was in the aerospace electric power business. They made starter-generators, dynamotors, alternators, transformer-rectifier units (TRUs), power converters and associated control units, primarily for aircraft. Part of the production test requirements was to verify the integrity of the insulation systems in these products. Insulation is necessary to isolate the current-carrying conductors from the iron laminations in the rotors and stators, and from the steel or aluminum equipment chassis.



and applied to the red DC test probe. R1-R4 will discharge C1 when the power is turned off. The DC test current follows the same path through the current sense circuit as the AC test mode. The custom-made voltage and milliamp meters have three studs rather than the usual two. One stud is the common and the other two are the connections for the AC and DC modes, switched through S1.

The Common (-DC) stud on voltmeter M1 is connected to the low side of step-down resistors R11-R15. Inside voltmeter M1, there is a full-wave bridge rectifier and a resistor calibration network connected in series. The meter movement and its parallel 133-Ω step-down divider resistor are connected directly across the dc output of the internal rectifier bridge. In the AC mode, the AC meter current is switched by S1 to the AC stud, then through the internal rectifier bridge across the meter movement. The R11-R15 divider completes the meter AC sensing circuit back at the

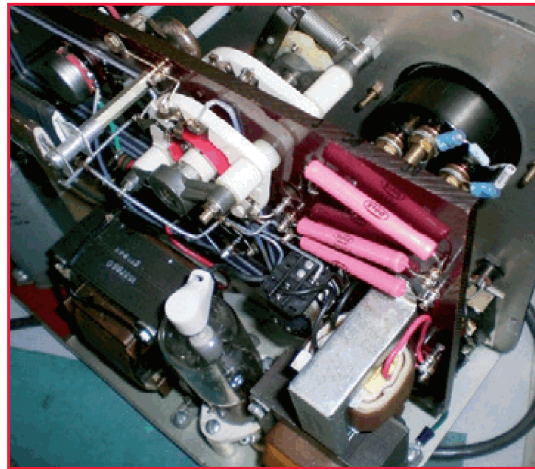

Figure 3. 60B4 internal construction.

Common stud. In DC mode, the +DC stud has an additional series calibration resistor pair from the +DC stud to the AC stud. From there the voltmeter circuit path is the same as for AC mode. In both AC and DC modes the meter current passes through the internal meter voltmeter full-wave

— Advertisement

elektor
PCB SERVICE
powered by Eurocircuits

25% Discount on new Elektor PCBs

Benefit now: Elektor PCB Service offers a permanent 90-day launch discount on new Elektor PCBs!

Check www.elektor.com/pcb for an overview of all Elektor PCBs

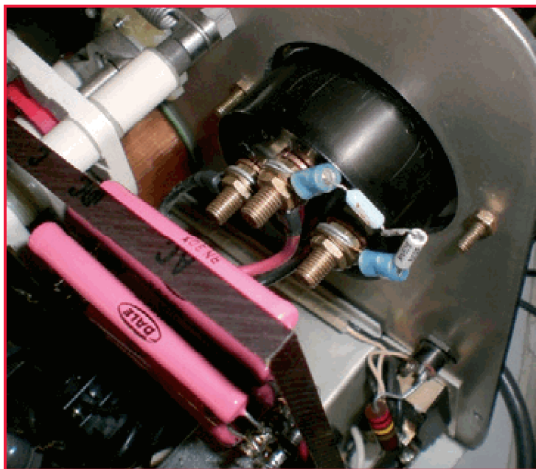

Figure 4.
60B4 more internal
construction

meter rectifier.

The M2 milliammeter also has an internal full-wave rectifier bridge and, as with the voltmeter, both AC and DC mode current pass through the rectifier bridge. The bridge is loaded by a current shunt resistor and the meter movement.

Internal Construction

Figure 3 shows the internal construction of the 60B4 Insulation Tester. The 3B24WB high-voltage rectifier tube is mounted between the three fixed transformers. The two large transformers were custom-built by Thordarson for Bendix. The smaller 5-volt transformer is a standard (now called COTS, for 'commercial-off-the-shelf') unit. All the other components are mounted on a thick piece of Micarta insulating material. The Dale power resistors on the right are R11-R15 step-down resistors for the M1 voltmeter, which is directly in front on the aluminum face plate. K1 relay is located below these resistors, next to the small transformer.

The rear wafer of the custom high-voltage S1

rotary switch, in the center of the photo, was built by Bendix Test Equipment department from aluminum oxide wafers and cylinders (Bendix Red Bank was also in the vacuum tube business from 1951-1962 and used lots of aluminum oxide for their tube element supports [1]). The switch has a notched nylon disk with a spring-loaded follower on the front panel for indexing the two AC and DC switch positions.

The large oil capacitor on the lower left is DC filter cap C1. The two large R7 and R8 wire-wound 91-watt bar resistors are mounted on long hex spacers above C1. The TRIP ADJ pot is directly in front of them. The CALIBRATE pushbutton switch and its actuator rod can be seen in front of the hex spacers.

The T1 voltage adjust variac windings can be seen in **Figure 4** just below the white front wafer switch insulators for S1. The voltmeter c, dc and ac stud connection designations are epoxy ink stamped on the top edge of the Micarta board. The corresponding wire connections to the voltmeter studs are shown. The neon indicator and resistor, the power switch and fuse are located on the lower right next to the probe compartment. This particular unit was apart because it needed a voltmeter recalibration. Disassembling the voltmeter to access the internal resistor network is delicate work, since the backing plate holding the two ¼ W metal-film resistors and four 1N4002 bridge diodes is part of the dial face, and it all has to be slipped past the meter needle to remove and replace it. The repairman wisely decided to put the new resistors on the rear +DC and AC studs. This will make it easier for the next repairman if the meter needs recalibration in the future. Finally, I should mention that the 60B4 is not qualified for testing to international safety standards IEC60950-1 or IEC60601-1.

(130251)

I'm shocked!

You might remember the AC-DC five-tube AM radios from the 1940's and 50's. It was common practice for the series-connected filaments and high voltage plate supply to be derived directly from the AC line voltage (115V or 220V). In the USA, line cord plugs were not polarized back then and three-prong AC sockets were rare, so if the plug was inserted backwards, the 115 VAC live voltage appeared on the steel chassis. If someone were to accidentally touch the chassis, they could get quite a good shock. Thus the radio's owner unwittingly served as a type of insulation tester.

Reference

- [1] *A Brief History of Bendix Red Bank Tubes*, Charles Hansen, ISBN 1-882580-50-8, Audio Amateur Press/Old Colony Sound Labs (now *audioXpress*, an Elektor International Media publication).

ORDERING INFORMATION

To order, contact customer service for your region:

USA / CANADA

Elektor US
111 Founders Plaza, Suite 300
East Hartford, CT 06108
USA
Phone: 860.289.0800
E-mail: service@elektor.com

Customer service hours:
Monday-Friday 8:30 AM-4:30 PM EST.

UK / ROW

Elektor International Media
78 York Street
London W1H 1DP
United Kingdom
Phone: (+44) (0)20 7692 8344
E-mail: service@elektor.com

Customer service hours:
Monday-Thursday 9:00 AM-5:00 PM CET.

PLEASE NOTE: *While we strive to provide the best possible information in this issue, pricing and availability are subject to change without notice. To find out about current pricing and stock, please call or email customer service for your region.*

COMPONENTS

Components for projects appearing in Elektor are usually available from certain advertisers in the magazine. If difficulties in obtaining components are suspected, a source will normally be identified in the article. Please note, however, that the source(s) given is (are) not exclusive.

TERMS OF BUSINESS

Shipping Note:

All orders will be shipped from Europe. Please allow 2-4 weeks for delivery.

Returns

Damaged or miss-shipped goods may be returned for replacement or refund. All returns must have an RA #. Call or email customer service to receive an RA# before returning the merchandise and be sure to put the RA# on the outside of the package. Please save shipping materials for possible carrier inspection. Requests for RA# must be received 30 days from invoice.

Patents

Patent protection may exist with respect to circuits, devices, components, and items described in our books, magazines, online publications and presentations. Elektor accepts no responsibility or liability for failing to identify such patent or other protection.

Copyright

All drawings, photographs, articles, printed circuit boards, programmed integrated circuits, discs, and software carriers published in our books and magazines (other than in third-party advertisements) are copyrighted and may not be reproduced (or stored in any sort of retrieval system) without written permission from Elektor. Notwithstanding, printed circuit boards may be produced for private and educational use without prior permission.

Limitation of liability

Elektor shall not be liable in contract, tort, or otherwise, for any loss or damage suffered by the purchaser whatsoever or howsoever arising out of, or in connection with, the supply of goods or services by Elektor other than to supply goods as described or, at the option of Elektor, to refund the purchaser any money paid with respect to the goods.

MEMBERSHIPS

Membership renewals and change of address should be sent to the Elektor Membership Department for your region:

USA / CANADA

Elektor USA
P.O. Box 462228
Escondido, CA 92046
Phone: 800-269-6301
E-mail: elektor@pcspublink.com

UK / ROW

Elektor International Media
78 York Street
London W1H 1DP
United Kingdom
Phone: (+44) (0)20 7692 8344
E-mail: service@elektor.com



Do you want to become an Elektor GREEN or GOLD Member or does your current Membership expire soon?

Go to www.elektor.com/member.

Hexadoku Puzzle with an electronic touch

For all of you who can't get enough of our special hexadecimalized Sudoku, here's a fresh puzzle for the long winter or hot summer evenings depending on where you are on the globe or in hyperspace. Find the solution in the gray boxes, submit it to us online, and you automatically enter the prize draw for one of four vouchers.

The Hexadoku puzzle employs numbers in the hexadecimal range 0 through F. In the diagram composed of 16 × 16 boxes, enter numbers such that **all** hexadecimal numbers 0 through F (that's 0-9 and A-F) occur once only in each row, once in each column and in each of the 4×4 boxes (marked by the thicker

black lines). A number of clues are given in the puzzle and these determine the start situation.

Correct entries received enter a prize draw. All you need to do is send us **the numbers in the gray boxes**.

Solve Hexadoku and win!

Correct solutions received from the entire Elektor readership automatically enter a prize draw for one Eurocircuits PCB voucher worth **\$140.00 (£80.00)** and three Elektor book vouchers worth **\$60.00 (£40.00)** each, which should encourage all Elektor readers to participate.

Participate!

Before January 1, 2014,

supply your personal details and the solution (the numbers in the gray boxes) to the web form at

www.elektor.com/hexadoku

Prize winners

The solution of the October 2013 Hexadoku is: **FCDE8**. The Eurocircuits \$140.00 (£80.00) voucher has been awarded to D. Jacobs (Germany). The Elektor \$60.00 (£40.00) book vouchers have been awarded to Gilbert Luyckx (Belgium), Esko Viruu (Finland); Walter Mei (Italy).

Congratulations everyone!

4	2			1			7	B			8			0	9
	3	B	F									E	A	2	
9						D			F						7
1			E		9					3		F			D
			1	9	0		C	2		8	F	D			
A		F	2	B	1					D	0	4	E		8
0			8	D		7	4	C	E		5	9			A
D	7													1	2
3		4	A	7							E	1	2		5
6	8		D								7		F	E	
		1	C	F	D					5	7	6	9		
F				8		1			3		6				0
			6		7					B		2			
		9		A	8					F	3		D		
7	F		4		C					2		5		E	B
C	5			0	B	F			1	E	D			9	6

F	0	5	4	E	9	3	8	2	D	7	B	1	6	A	C
1	3	8	C	5	A	B	0	E	F	9	6	2	4	7	D
2	A	D	6	F	1	C	7	3	0	4	8	B	5	9	E
7	9	B	E	2	4	D	6	1	5	A	C	3	8	F	0
0	1	E	F	3	2	A	4	B	C	5	7	8	9	D	6
C	B	3	D	1	8	5	F	9	2	6	0	A	7	E	4
4	7	2	5	6	B	9	E	8	A	D	1	C	F	0	3
A	6	9	8	0	C	7	D	4	3	F	E	5	B	2	1
8	E	6	7	4	F	1	5	C	B	2	9	D	0	3	A
9	4	F	2	7	6	0	A	5	1	3	D	E	C	B	8
5	C	0	3	8	D	2	B	6	7	E	A	F	1	4	9
B	D	A	1	C	3	E	9	F	8	0	4	6	2	5	7
3	5	7	A	9	E	8	1	0	6	B	F	4	D	C	2
6	2	4	0	A	7	F	C	D	E	8	5	9	3	1	B
D	F	1	9	B	0	6	2	A	4	C	3	7	E	8	5
E	8	C	B	D	5	4	3	7	9	1	2	0	A	6	F

The competition is not open to employees of Elektor International Media, its business partners and/or associated publishing houses.

Retronics Personified

By Gerard Fonte (USA)

Reading the *Retronics* pages in *Elektor* got me thinking about my 50 years in electronics. I started at age twelve and was lucky to experience the transformation from tubes to transistors to integrated circuits to personal computers to embedded computers and to the Internet. I don't think any 50-year period has seen such a transformation in any craft in history. And I don't think it's likely to happen again.

In the Beginning

A kid without much money had a hard time getting parts for projects. But unlike today, old radios and TVs could be disassembled and their parts reused. In a few years I had drawers of recycled tubes and transformers and hundreds of resistors and capacitors. Of course these parts were nowhere near the quality of today's parts. Standard resistors had 20% tolerance. Worse, these components were screened to remove the 10% and 5% parts which sold at a better price. So your 1000-ohm resistor was either 800 to 900 ohms or 1100 to 1200 ohms. It's amazing that anything worked at all.

Most experimenters only had a VOM (Volt-Ohm-Milliammeter) or VTVM (Vacuum-Tube-Volt-Meter) for instrumentation. And they were expensive. My VOM cost \$29.95 in 1967 (\$216 today) and I mailed in a \$5.00 payment for 6 months. There were no bank credit cards in those days. I had an after-school job as a stock-boy (now "stock-clerk") in a local drugstore that paid \$1.85 an hour. (I knew that it would only give my parents a good laugh if I asked them to pay for it.)

In a few years I was able to acquire the Holy Grail of instruments—an oscilloscope! It cost \$129 as a kit (Eico 460) and was a "wide-band" 'scope that could respond all the way up to 5 MHz. My parents tried hard to talk me out of wasting my money with this expensive instrument. But they couldn't. And in the long run I think that they agreed that I got my money's worth from it. Electronics was not just another passing fad for me. The projects of those days were very simple when compared to today. After all, what could you do with a just couple of tubes or transistors? There were uncounted variations of oscillators and amplifiers and simple radios. Amateur radio (Ham Radio) was a big thing. Everybody had a short-wave radio of some sort if they were "serious" about electronics. That meant lots of experimentation with antennas. This was both a simple and complex topic. There was considerable math in regards to optimal length for a particular frequency, etc. But, that was generally ignored. It was much more fun to build strange and wonderful creations and then climb out onto the roof to try them out.

A Different World

In 1961 the US invaded Cuba (Bay of Pigs). In 1962 there was the Cuban Missile Crisis where the US and the Soviet Union came within a hair's-breadth of full-scale nuclear war. In 1963 President Kennedy was assassinated. The 60's was the time of hippies and the "counterculture". There were three TV channels (ABC, CBS and NBC). Color TV, stereo phonographs and FM radio were just coming into their own.

Getting involved in electronics was easy. All you really needed was a 150-watt soldering gun (nobody used irons—they were much too weak). There were many more magazines about electronics, radio and TV than now. The public library was a major asset.

Nowadays it's much harder. First you have to pick a specialty. Are you interested in computers? If so, then there are the subsets of PC's or embedded with operating systems of Linux or Windows. Or computer hardware versus software. And then there are the "Apps" for various phones and pads. It takes a great deal of effort just to find out if an area is interesting. No hobbyist had a specialty fifty years ago. There wasn't even much specialization in the profession of electrical engineering.

The Internet is such a fantastic tool that didn't exist then. First and foremost is the access to so much information. It doesn't matter if you are an electronics novice or an expert, you can find what you need with a few keystrokes. Back then, you had to write a letter to the company and hope that they would mail you a catalog.

Curiously, there were many more stores that sold electronic parts than today—probably because electronics was much less reliable then. There was Olsen, Lafayette and Tandy/Radio-Shack among others. So you could go downtown to buy resistors or capacitors for your project in an afternoon. Otherwise, you would have to mail-order them. Yes, snail-mail was a lot bigger in those days. (Fed-Ex didn't exist and UPS was not national.) The company typically mailed parts out at the end of the month or whenever they felt like it (whichever was longer). It was not unusual to wait six weeks or more for your parts to arrive.

Unchanging

However there is one thing that hasn't changed a bit in fifty years: that's the curiosity and energy of hobbyists. People of all ages are still eager to learn and do new things. We form communities to share our knowledge and experience with others. We push the envelope to build amazing creations and advance the state of the art for our own enjoyment. We are relentless in our pursuit of enlightenment. This doesn't occur very much in other areas of science (perhaps astronomy). So electronic hobbyists are a special breed. And, that's something to be proud about.

(130387)

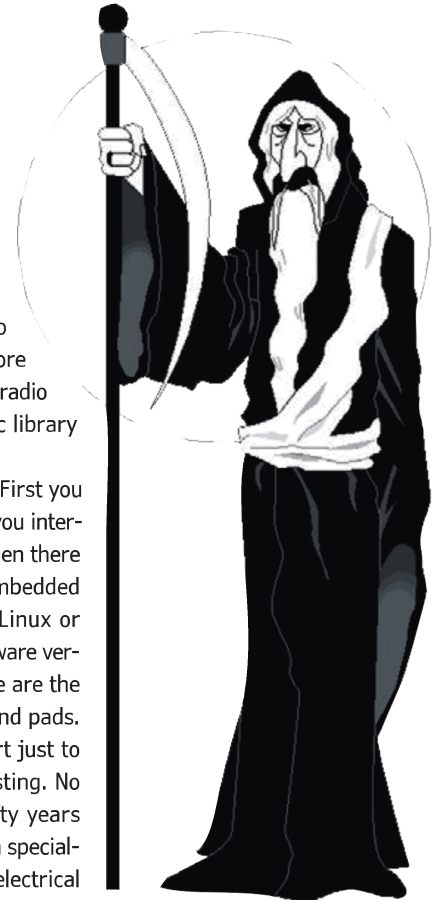

NEW

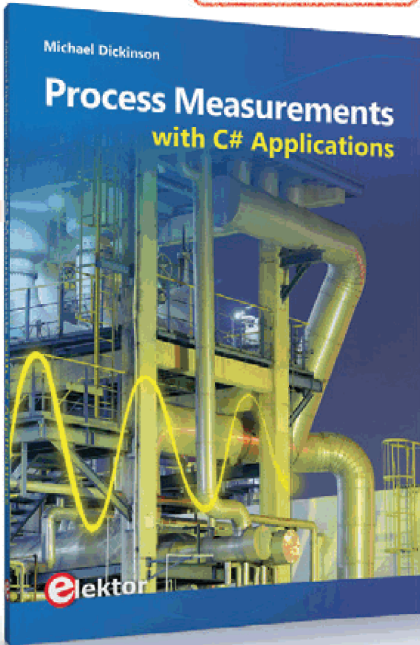

1

10% DISCOUNT
for GREEN and GOLD Members!
www.elektor.com/books

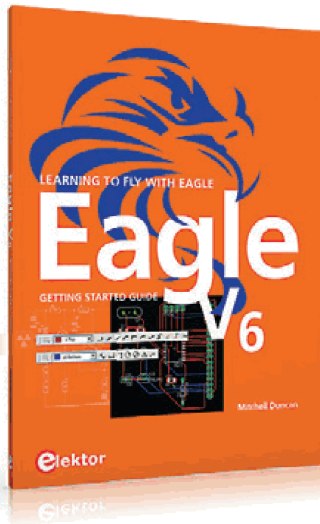

2

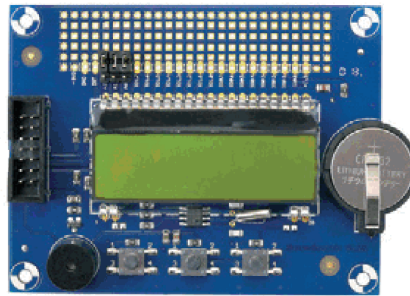

4

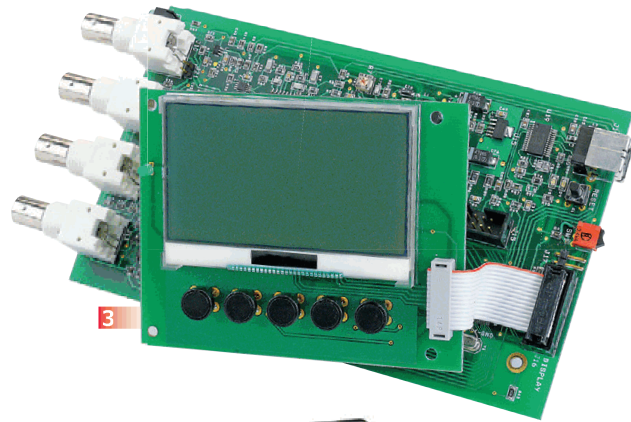

3



5

1 Process Measurements with C# Applications

Measurement is vital to the successful control of any process. This book introduces PC based measurement systems and software tools for those needing to understand the underlying principles or apply such techniques. Throughout the book, the C# programming language is used to give the reader immediate practical desktop involvement. C-Sharp has a wide support base and is a popular choice for engineering solutions. The basics of measurement and data capture systems are presented, followed by examples of software post-processing. Application examples are provided from a range of process industries, with reference to remote monitoring, distributed systems and current industrial practices.

144 pages • ISBN 978-1-907920-24-0
£24.50 • € 27.50 • US \$39.50

Learning to fly with Eagle
2 EAGLE V6 Getting Started Guide

This book is intended for anyone who wants an introduction to the capabilities of the CadSoft's EAGLE PCB design software package. This book will quickly allow you to obtain an overview of the main modules of EAGLE: the schematic editor; layout editor and

autorouter in one single interface. You will apply your knowledge of EAGLE commands to a small project, learn more about some of the advanced concepts of EAGLE and its capabilities and understand how EAGLE relates to the stages of PCB manufacture. After reading this book while practicing some of the examples, and completing the projects, you should feel confident about taking on more challenging endeavors.

208 pages • ISBN 978-1-907920-20-2
£29.50 • € 34.50 • US \$47.60

The luxury of precision within everyone's reach
3 500 ppm LCR Meter

The remarkable precision of this device and its amazing ease of use are the result of careful design. It works so well behind its uncluttered front panel that one could almost forget the subtleties of the measurement techniques employed. A dream opportunity for our readers who are passionate about measurement to enjoy themselves. If, like us, you wonder at the marvels modern techniques bring within our reach, come along and feel the tiny fraction of a volt.

Set: main board and LCD board, assembled and tested
Art.# 110758-93
See www.elektor.com/lcrmeter

Display, buttons, real time clock and more

4 Elektor Linux Board Extension

This extension board was developed to further propel our Embedded Linux series of articles and the matching GNUblin board. It has a display, buttons, a real time clock and 16 GPIOs. Linux devotees, switch on your solder irons. The Linux extension board includes everything needed to provide the user interface for a wide variety of projects!

Module, SMD-populated and tested board, incl. LCD1, X1, K1-K4, BZ1, BT1 for home assembly
Art.# 120596-91
£31.10 • € 34.95 • US \$50.20

140 Minutes video presentation and more

5 DVD Feedback in Audio Amplifiers

In this Masterclass we address several aspects of feedback in audio amplifiers. The focus of this Masterclass, although not entirely math-free, is on providing insight and understanding of the issues involved. Presenter Jan Didden provides a clear overview of the benefits that can be obtained by feedback and its sibling, error correction; but also of its limitations and disadvantages. Recommended to audio designers and

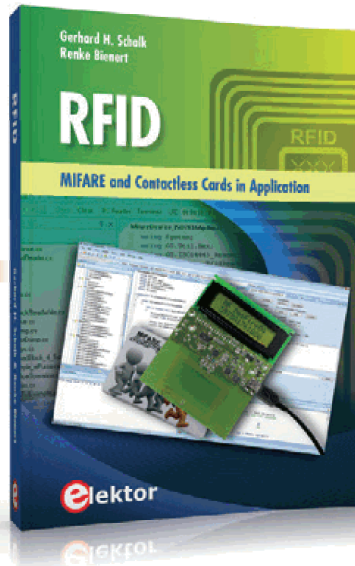
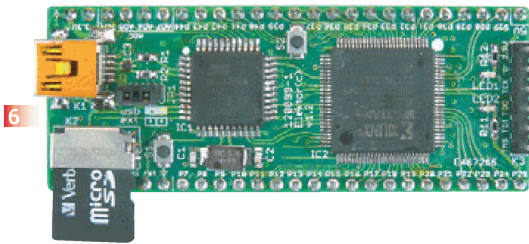

serious audio hobbyists!

ISBN 978-907920-16-5

£24.90 • € 29.95 • US \$40.20

Taming the Beast

FPGA Development Board

FPGAs are unquestionably among the most versatile but complex components in modern-day electronics. An FPGA contains a maze of gates and other circuit elements that can be used to put together your own digital circuit on a chip. This FPGA development board (designed in the Elektor Labs) shows how easy it is for any electronics enthusiast, whether professional or amateur, to work with these programmable logic devices.

Module, ready build and tested

Art.# 120099-91

See www.elektor.com/fpgaboard

Programming step-by-step

Android Apps

This book is an introduction to programming apps for Android devices. The operation of the Android system is explained in a step by step way, aiming to show how personal applications can be programmed. A wide variety of applications is presented based on a solid number of hands-on examples, covering anything from

simple math programs, reading sensors and GPS data, right up to programming for advanced Internet applications. Besides writing applications in the Java programming language, this book also explains how apps can be programmed using Javascript or PHP scripts. When it comes to personalizing your smartphone you should not feel limited to off the shelf applications because creating your own apps and programming Android devices is easier than you think!

244 pages • ISBN 978-1-907920-15-8

£34.95 • € 39.95 • US \$56.40

MIFARE and Contactless Cards in Application

RFID

MIFARE is the most widely used RFID technology, and this book provides a practical and comprehensive introduction to it. Among other things, the initial chapters cover physical fundamentals, relevant standards, RFID antenna design, security considerations and cryptography. The complete design of a reader's hardware and software is described in detail. The reader's firmware and the associated PC software support programming using any .NET language. The specially developed PC program, "Smart Card Magic.NET", is a simple development environment that supports sending commands to a card at the click of a mouse, as well as the ability

to create C# scripts. Alternatively, one may follow all of the examples using Visual Studio 2010 Express Edition. Finally, the major smart card reader API standards are introduced. The focus is on programming contactless smartcards using standard PC/SC readers using C/ C++, Java and C#.

484 pages • ISBN 978-1-907920-14-1

£44.90 • € 49.90 • US \$72.50

t

More than 75,000 components

ECD 7 Elektor's Components Database

This CD-ROM gives you easy access to design data for over 11,100 ICs, 37,000 transistors, FETs, thyristors and triacs, 25,100 diodes and 2,000 optocouplers. The program package consists of eight databanks covering ICs, transistors, diodes and optocouplers. A further eleven applications cover the calculation of, for example, zener diode series resistors, voltage regulators, voltage dividers and AMV's. A colour band decoder is included for determining resistor and inductor values. All databank applications are fully interactive, allowing the user to add, edit and complete component data.

ISBN 978-90-5381-298-3

£24.90 • € 29.50 • US \$40.20



Wireless and button-free

10 **Android Elektorcardioscope**

Instructive, fascinating, and potentially useful to everyone: perform your own electrocardiograms on your Android smartphone or tablet! The project involves skillfully combining a small PIC interface to control an analog input stage with a great deal of software.

Our ECG interface is available in the form of a ready-to-use module to which you just have to add four electrodes and an Android application for smartphone or tablet; there's no physical connection between this terminal and the interface, as it uses Bluetooth communication!

Ready assembled board

Art.# 120107-91

See www.elektor.com/elektorcardioscope

11 **110 issues, more than 2,100 articles**
DVD Elektor 1990 through 1999

This DVD-ROM contains the full range of 1990-1999 volumes (all 110 issues) of Elektor Electronics mag-

azine (PDF). The more than 2,100 separate articles have been classified chronologically by their dates of publication (month/year), but are also listed alphabetically by topic. A comprehensive index enables you to search the entire DVD. What's more, this DVD also contains the entire 'The Elektor Datasheet Collection 1...5' CD-ROM series, with the original full datasheets of semiconductors, memory ICs, microcontrollers, and much more.

ISBN 978-0-905705-76-7

£69.00 • € 89.00 • US \$111.30

12 **Concept, implementation and assessment**
Designing Tube Amplifiers

This book looks at tube amplifiers from more than just a theoretical perspective. It focuses primarily on the design phase, where decisions must be taken with regard to the purpose and requirements of the amplifier, and it addresses the following questions: How do these aspects relate to subjective and objective criteria? Which circuits sound the best, and why? If you want to develop and market an amplifier, what problems should you expect? What are the significance and meaning of measurements? Are they still meaningful, or have they

lost their relevance? Thanks to the enormous processing power of computers, we can now measure more details than ever before. How can these new methods be applied to tube amplifiers? Menno van der Veen will give you all the answers!

188 pages • ISBN 978-1-907920-22-6

£29.50 • € 34.50 • US \$47.60

Helped By Arduino
Mastering Microcontrollers

The aim of this book is not only to let you enter the World of Arduino, but also to help you emerge victorious and continue your microcontroller programming learning experience by yourself. In this book theory is put into practice on an Arduino board using the Arduino programming environment.

Having completed this fun and playful course, you will be able to program any microcontroller, tackling and mastering I/O, memory, interrupts, communication (serial, I²C, SPI, 1-wire, SMBus), A/D converter, and more. This book will be your first book about microcontrollers with a happy ending!

348 pages • ISBN 978-1-907920-23-3

£34.95 • € 39.95 • US \$56.40

NEW

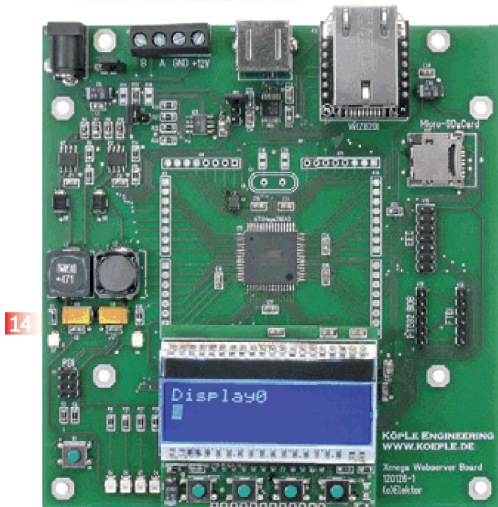

14

Display, SD card, Ethernet, RS-485, buttons and LEDs

14 XMEGA Web Server Board

This microcontroller board is particularly well suited to monitoring and control applications. The plug-in TCP/IP module allows you to implement a web server and other network-oriented applications and a microSD card provides mass storage. Four LEDs, four buttons, and a removable display provide the user interface options. And of course the board comes with a wide range of external interfaces.

Controller Module

Art.# 120126-91

See www.elektor.com/xmega

LabWorX 2

15 Mastering Surface Mount Technology

This book takes you on a crash course in techniques, tips and know-how to successfully introduce surface mount technology in your workflow. Even if you are on a budget you too can jumpstart your designs with advanced fine pitch parts. Besides explaining methodology and equipment, attention is given to SMT parts technologies and soldering methods. Many practical



15

Companion DO IT YOURSELF Kits available
www.elektor.com/labworx

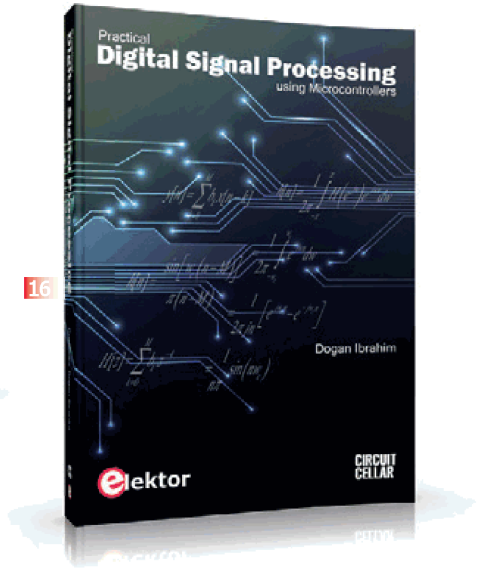

16

tips and tricks are disclosed that bring surface mount technology into everyone's reach without breaking the bank. A comprehensive kit of parts comprising all SMT components, circuit boards and solder stencils is available for readers wishing to replicate three projects described in this book.

282 pages • ISBN 978-1-907920-12-7

£29.50 • € 34.50 • US \$47.60

Ideal reading for students and engineers

16 Practical Digital Signal Processing using Microcontrollers

This book on Digital Signal Processing (DSP) reflects the growing importance of discrete time signals and their

use in everyday microcontroller based systems. The author presents the basic theory of DSP with minimum mathematical treatment and teaches the reader how to design and implement DSP algorithms using popular PIC microcontrollers. The author's approach is practical and the book is backed with many worked examples and tested and working microcontroller programs. The book should be ideal reading for students at all levels and for the practicing engineers who may want to design and develop intelligent DSP based systems. Undergraduate students should find the theory and the practical projects invaluable during their final year projects. Similarly, postgraduate students should be able to develop advanced DSP based projects with the aid of the book.

428 pages • ISBN 978-1-907920-21-9

£44.90 • € 49.90 • US \$72.50

Further Information and Ordering: www.elektor.com/store or contact customer service for your region

UK / ROW

Elektor International Media
78 York Street
London - W1H 1DP United Kingdom
Phone: +44 20 7692 8344
E-mail: service@elektor.com

USA / CANADA

Elektor US
111 Founders Plaza, Suite 300
East Hartford, CT 06108 USA
Phone: 860.289.0800
E-mail: service@elektor.com

NEXT MONTH IN ELEKTOR MAGAZINE

Extra Thick Double January & February 2014 Edition

Traditionally Elektor's first edition of the year is a double one with extra load of projects, ideas and tips. The scope is varied and consists of a mix of large and small items. Of course there are various microcontroller projects, but there is also room for measurement and control projects, analog electronics such as audio amplifiers, and small experimental stuff. Apart from the two mainline projects below you can look forward to seeing:

- RS485 Module
- Electronic Rain Gauge
- Flow Probe
- Adjustable DC Power source
- Wireless Power Transfer
- 12-V LED Dimmer
- DDS Function Generator
- 3D Printer
- General Purpose DSP Board

(titles subject to change)

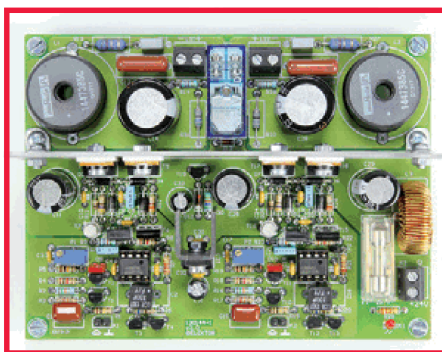

Class-D 555'd Audio Power Stage

Class-D power amplifiers are no longer a novelty. You can get them with discrete components as well as with special ICs. In our case however the idea was to check out the popular 555 timer IC as the basis for an audio amplifier. That has resulted in a fun and easy to build stereo design with a power output of approximately 6 watts. It all goes to show that class D is not necessarily 'exotic' or 'difficult'.

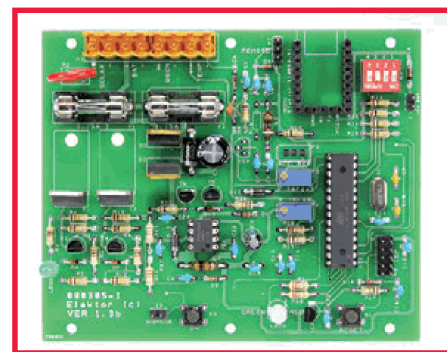

Solar cell-charge controller

This arrangement was originally designed for powering a small weather station, but it is also suitable for other low-power applications. The circuit is suitable for 12-V solar panels rated between 10 and 50 watts and can easily be adapted for larger capacities. To ensure high efficiency a switching power supply is used, also benefiting from very low dissipation. The charging process is accurately controlled by a microcontroller.

Article titles and magazine contents subject to change, please check the Magazine tab at www.elektor.com
Elektor January & February 2014 is processed for mailing to US, UK and ROW Members starting January 8, 2014.

See what's brewing
@ Elektor Labs 24/7

Check out
www.elektor-labs.com
and join, share, participate!

Travel Essentials*

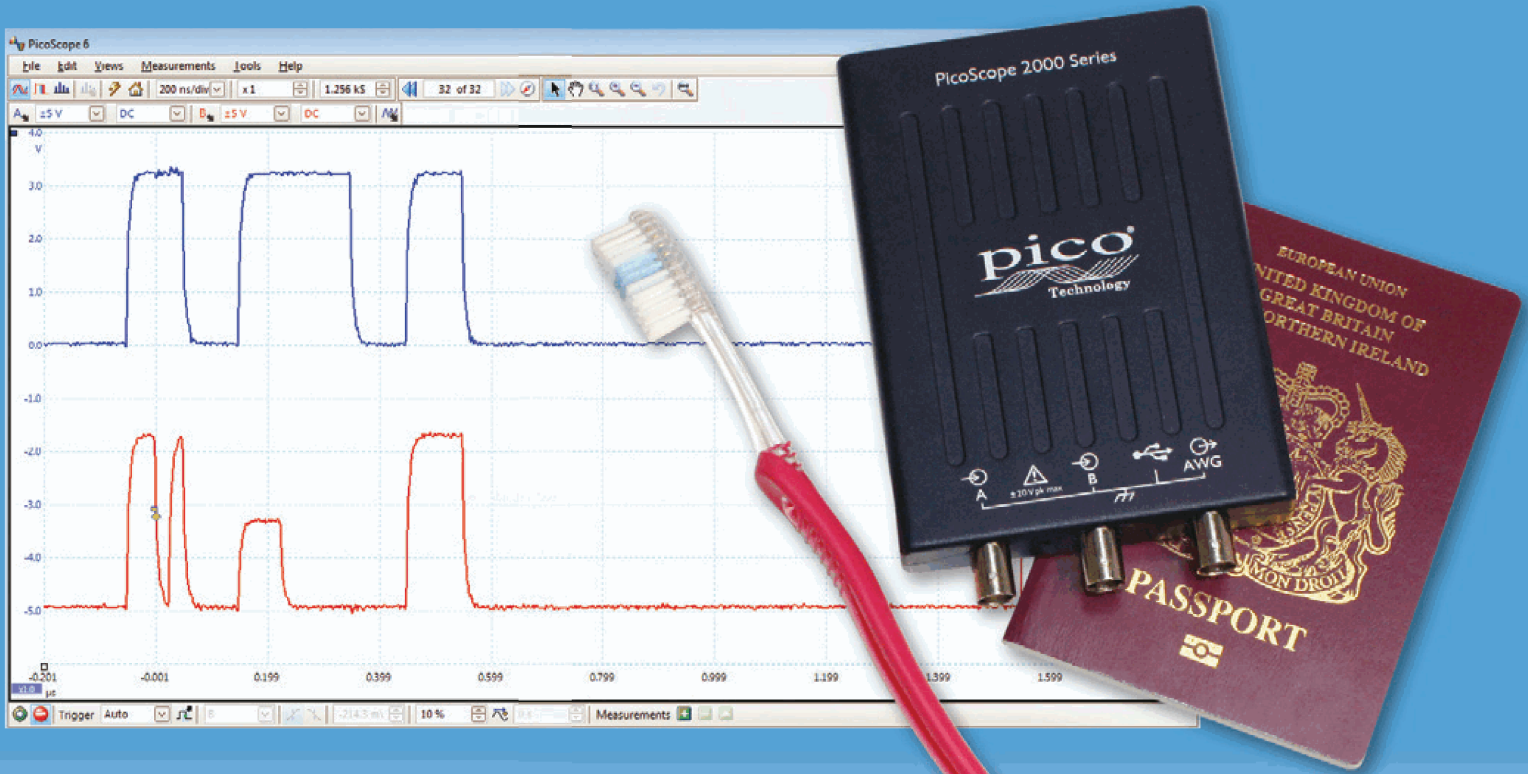

PC Oscilloscope

MEASUREMENTS & STATISTICS
UART

up to 200 MHz

I²C from £159

1 GS/s

AWG

SPECTRUM ANALYZER

I²S

Serial decoding

SPI

MATH CHANNELS

Advanced triggers

PERSISTENCE DISPLAY

LIN

COLOR PERSISTENCE

Mask tests FFT

www.picotech.com/PS238

*Dont forget your toothbrush

CAD CONNECTED

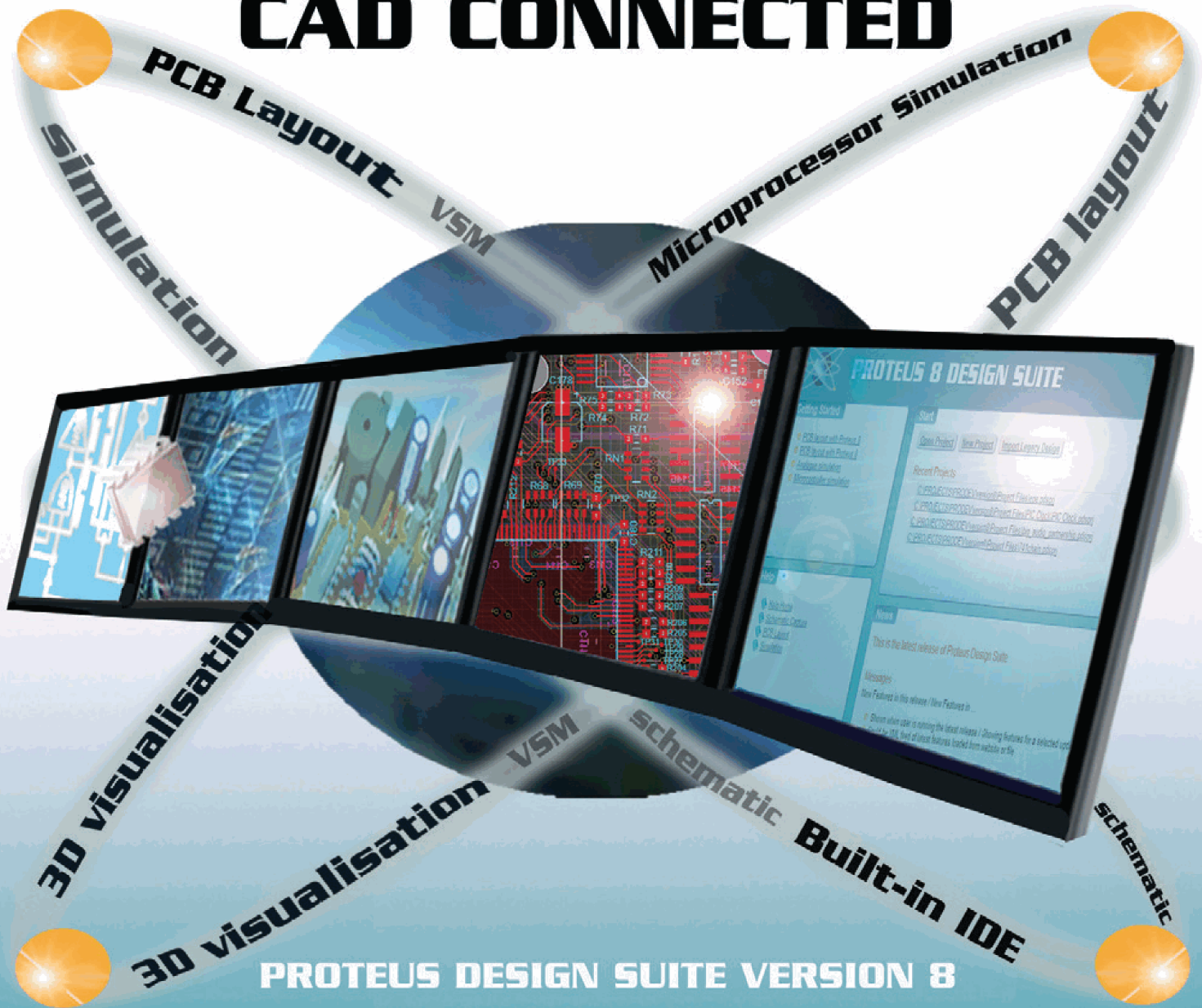

PROTEUS DESIGN SUITE VERSION 8

Featuring a brand new application framework, common parts database, live netlist and 3D visualisation, a built in debugging environment and a WYSIWYG Bill of Materials module, Proteus 8 is our most integrated and easy to use design system ever. Other features include:

- . Hardware Accelerated Performance.
- . Unique Thru-View™ Board Transparency.
- . Over 35k Schematic & PCB library parts.
- . Integrated Shape Based Auto-router.
- . Flexible Design Rule Management.
- . Polygonal and Split Power Plane Support.
- . Board Autoplacement & Gateswap Optimiser.
- . Direct CAD/CAM, ODB++, IDF & PDF Output.
- . Integrated 3D Viewer with 3DS and DXF export.
- . Mixed Mode SPICE Simulation Engine.
- . Co-Simulation of PIC, AVR, 8051 and ARM MCUs.
- . Direct Technical Support at no additional cost.

**Version 8.1 has now been released
with a host of additional exciting new features.**

For more information visit.

www.labcenter.com